



Sawtooth Control

J. P. Graves
CRPP, EPFL, Switzerland

B. Alper¹, I. Chapman², S. Coda, M. de Baar³, L.-G. Eriksson⁴, R. Felton¹, D. Howell², T. Johnson⁵, V. Kiptily¹, R. Koslowski⁶, M. Lennholm¹, M.-L. Mayoral¹, I. Monakhov¹, I. Nunes⁷, J. Paley, S. D. Pinches², O. Sauter, C. Zucca and JET-EFDA contributors*

¹JET-EFDA, Culham Science Centre, OX14 3DB, Abingdon, UK

²EURATOM-UKAEA Fusion Association, Culham Science Centre, United Kingdom

³FOM Instituut voor Plasmafysica “Rijnhuizen,” Association EURATOM-FOM, The Netherlands

⁴European Commission, Directorate General for Research, Unit J4 - Fusion Associations Agreement

⁵Association EURATOM-VR, EES, KTH, Stockholm, Sweden

⁶Forschungszentrum Jülich GmbH Institut für Energieforschung - Plasmaphysik 52425 Jülich, Germany

⁷Associação EURATOM/IST, 1049-001, Lisboa, Portugal

*See appendix of F. Romanelli et al., Proceedings of the 22nd IAEA Fusion Energy Conference 2008, Geneva, Switzerland.

J. P. Graves, IISS, Austin, 31 May – 4 June 2010



Introduction to Sawteeth

Sawtooth cycle [S. von Goeler, PRL, 1974] divided into three phases:

- Sawtooth ramp: density, temperature and current density increase in the core.
- Sometimes a precursor phase: growing MHD instability with internal kink ($n=m=1$) structure.
- Collapse phase: density, temperature and current peaking in the core collapses

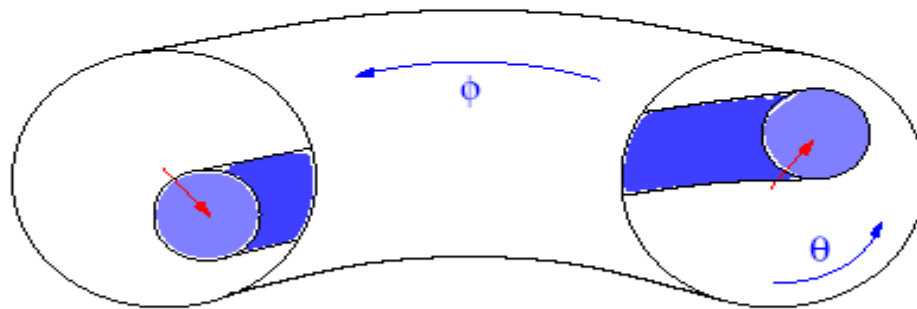

Tilt and shift plasma displacement $\sim \exp(i\theta - i\phi - i\omega t)$

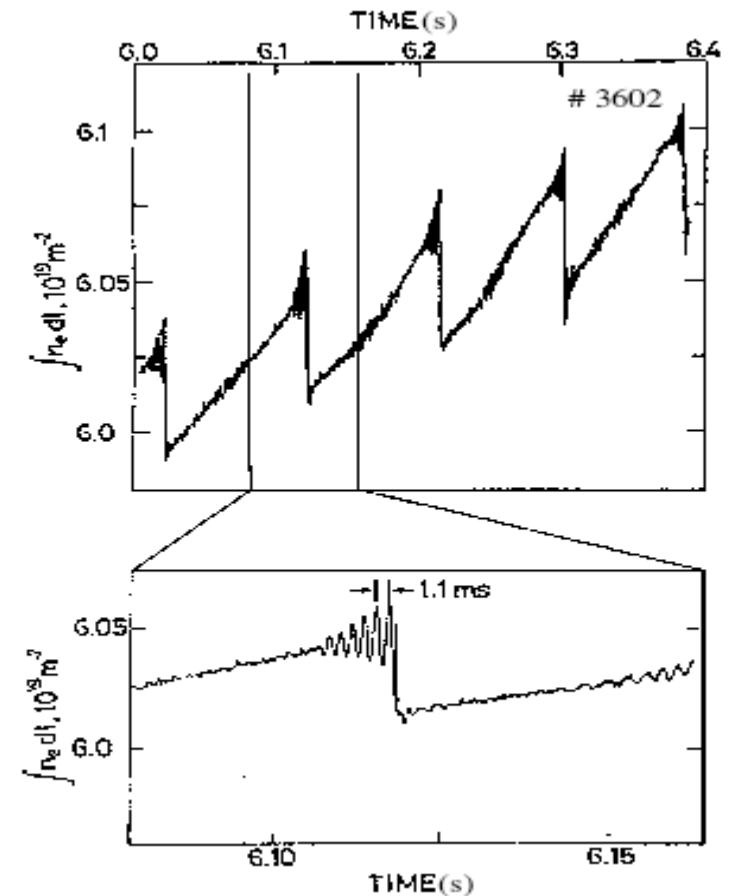



Benefits of Sawtooth Lengthening

Sawteeth with long inter-crash times (long period) are expected to permit improved performance - gradients can build up and stored energy increase.

In JET it was found that long sawteeth were routinely generated with strong auxiliary heating of fast ions, especially with ICRH

Sawtooth crash occurred within slowing down time of energetic ions following rapid switch off of ICRH.

Strong evidence that the fast ions were responsible. Theory demonstrated the stabilising role of trapped energetic ions

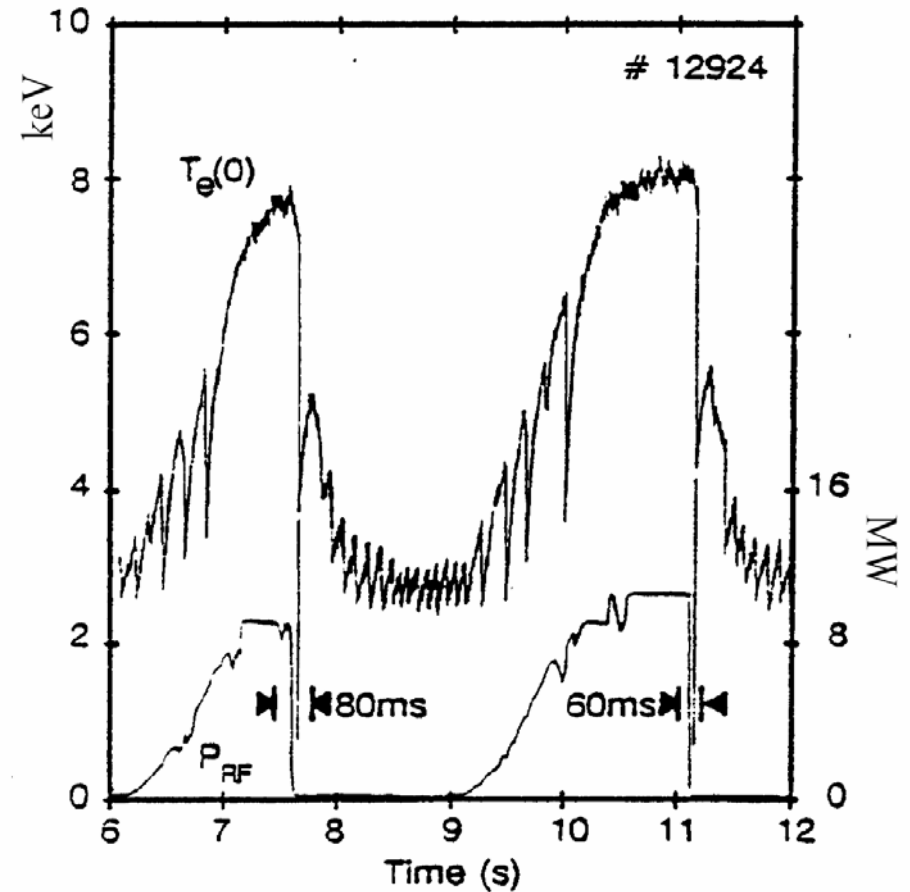

D.Campbell, EPS Proceedings 1988

J. P. Graves, IISS, Austin, 31 May – 4 June 2010





Benefits of Sawtooth Lengthening

The improved performance with long sawteeth led many machines to attempt to routinely obtain sawteeth as long as possible

A major motivation for JET and TFTR was preparation of DT - fusion pulses. Both attempting world record fusion power.

Best hope of large fusion power: transient DT fusion phase (within maximum sawtooth free phase ~ 2 s).

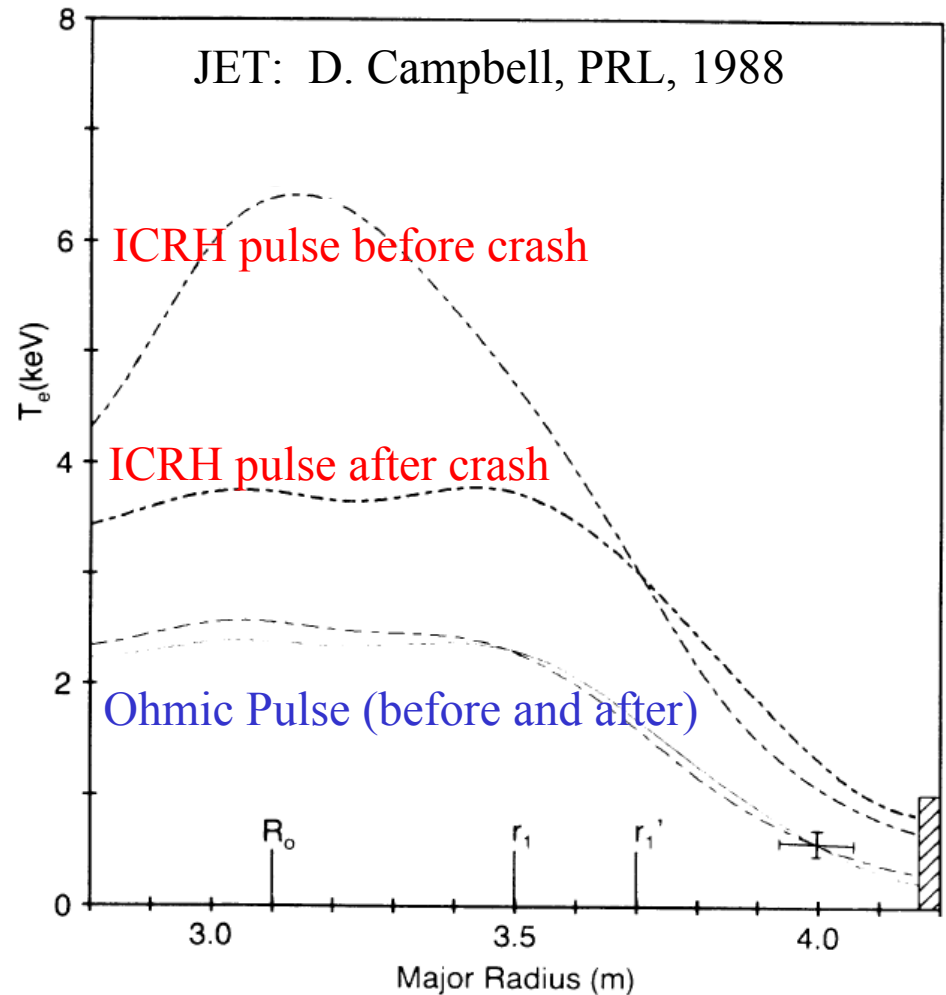



Fusion Power and Sawtooth Period

Two similar consecutive JET pulses.

The second is absent of sawteeth, and a fusion power world record was obtained.

In the first pulse, the stored energy and fusion power stopped rising after the sawtooth crash.

This indicates the benefit of long sawteeth. **But, why didn't the rise in stored energy and fusion power recover?**

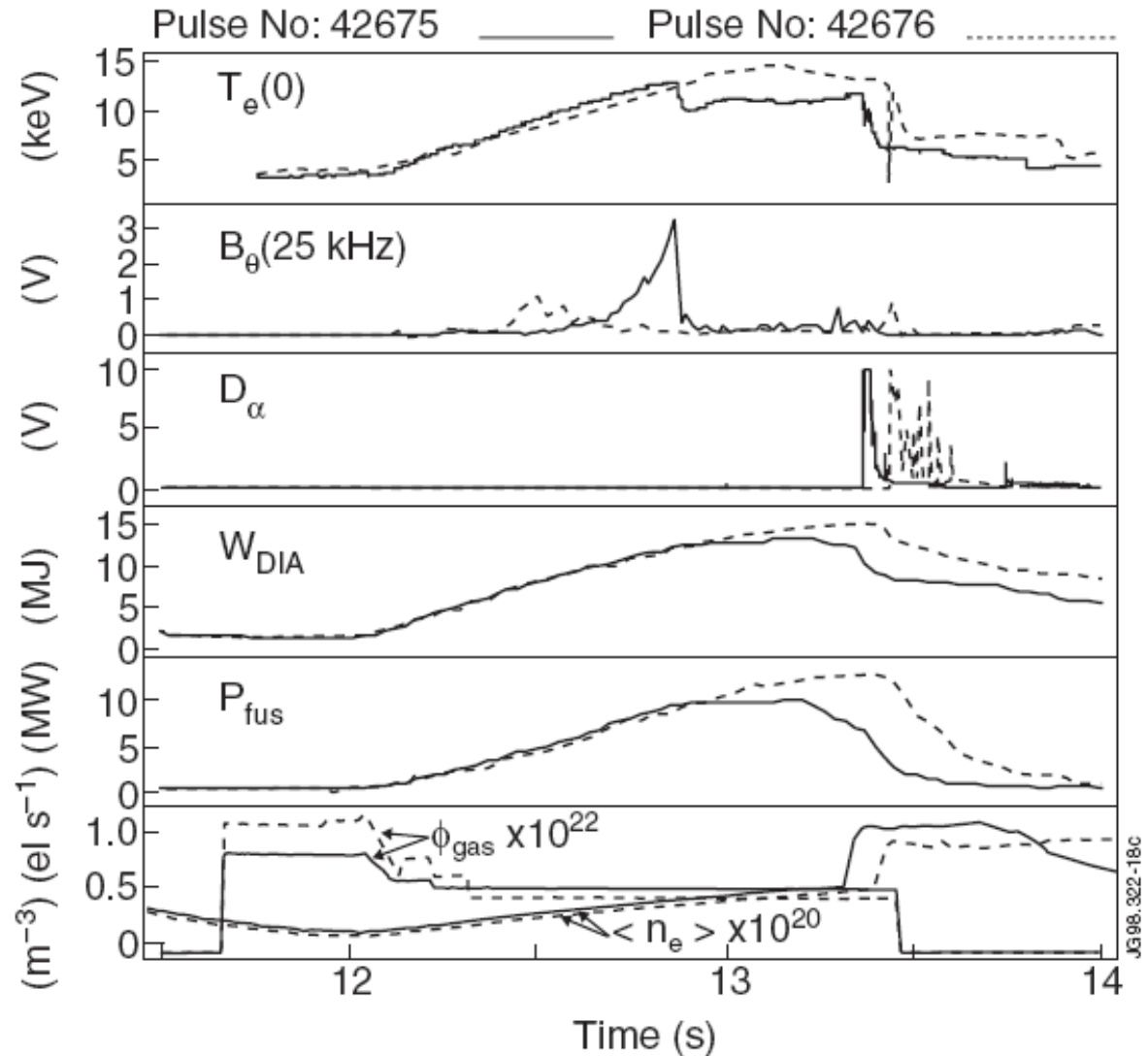

F. Nave, NF (2002)

J. P. Graves, IISS, Austin, 31 May – 4 June 2010





Link Between Sawteeth and NTMs

It appears that the reason why 62675 did not achieve record transient fusion power was because the sawtooth crash triggered secondary, long-lasting MHD activity.

At the sawtooth crash, an $n=3$, $m=4$ neoclassical tearing mode was triggered on the $q=4/3$ magnetic surface.

These large saturated island structures impair energy and particle confinement, and can in some cases, disrupt the plasma.

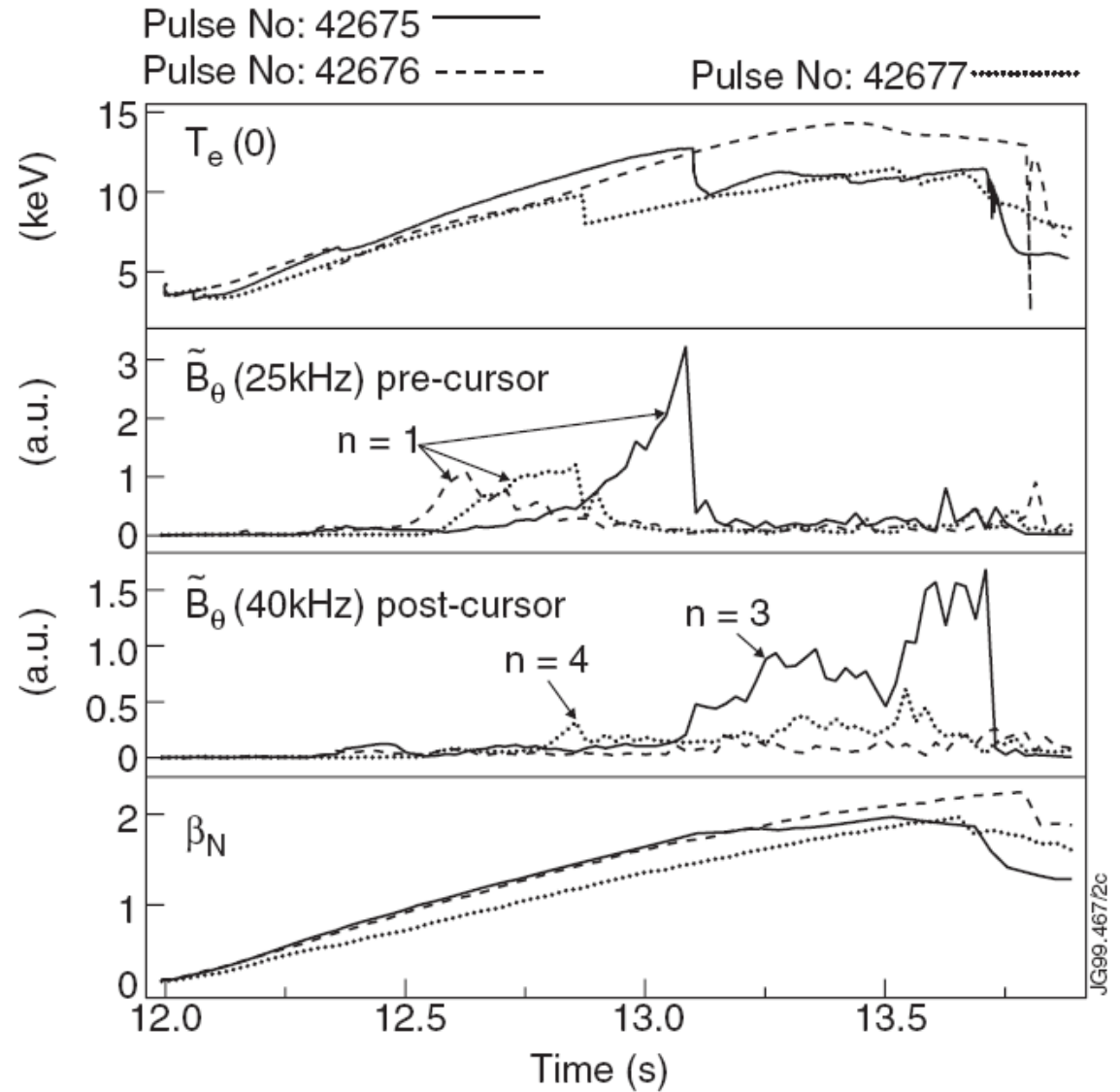

F. Nave, NF (2002)

J. P. Graves, IISS, Austin, 31 May – 4 June 2010





NTMs degrade plasma confinement

- NTM's can cause ~15-20% drop in confinement

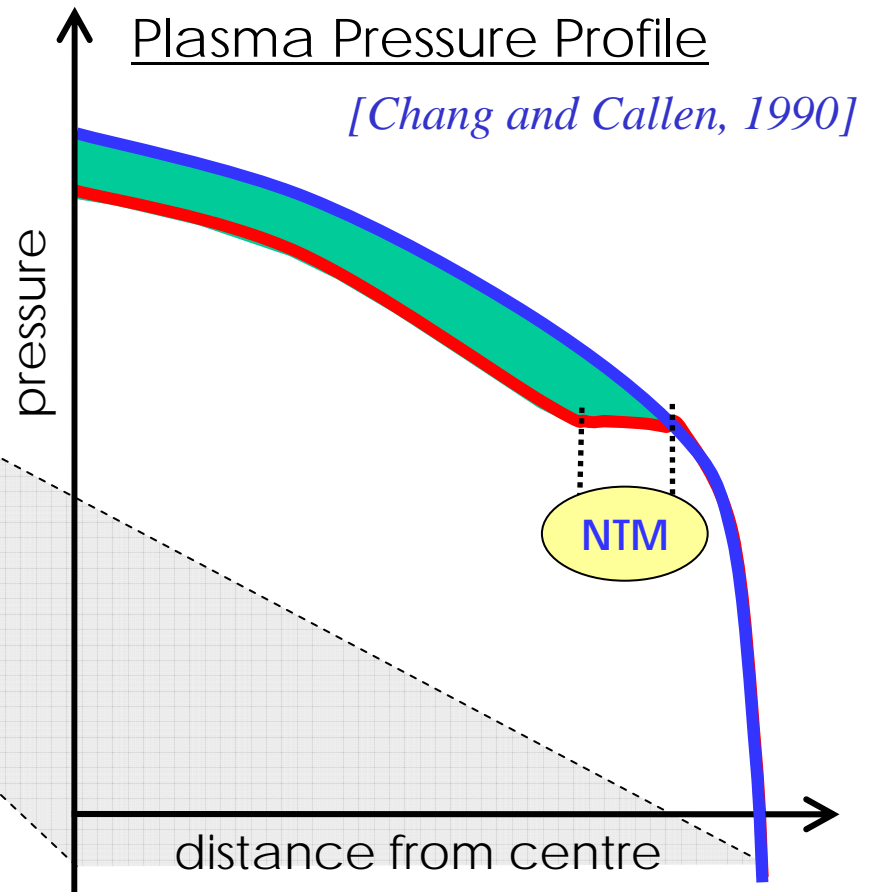
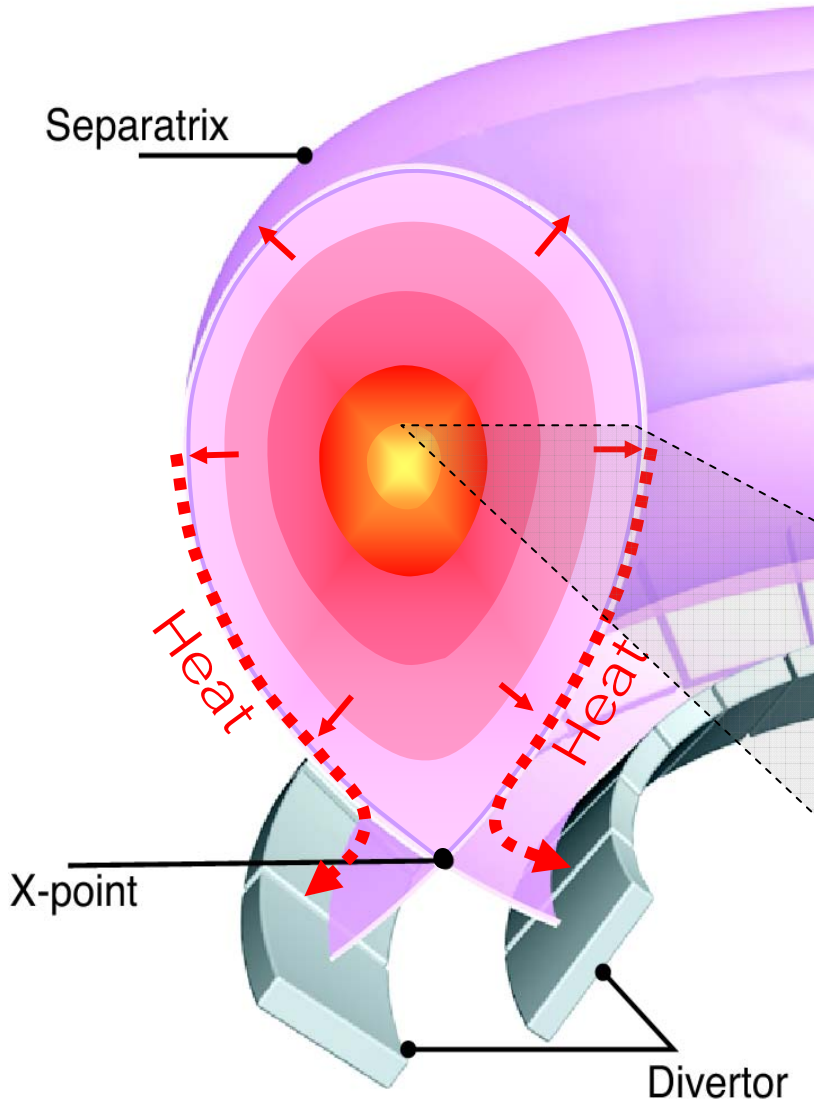



Safety Control of NTM in JET

In order to mitigate the possibility of disruption, there are real-time safety stems, which act quickly in response to an island that has become 'too large'.

In this recent example, a long sawtooth triggered an NTM in low-confinement mode.

When the amplitude of the $n=2$ went over a standard pre-determined safety threshold, the auxiliary power was switched off, and the current, field and density ramped down.

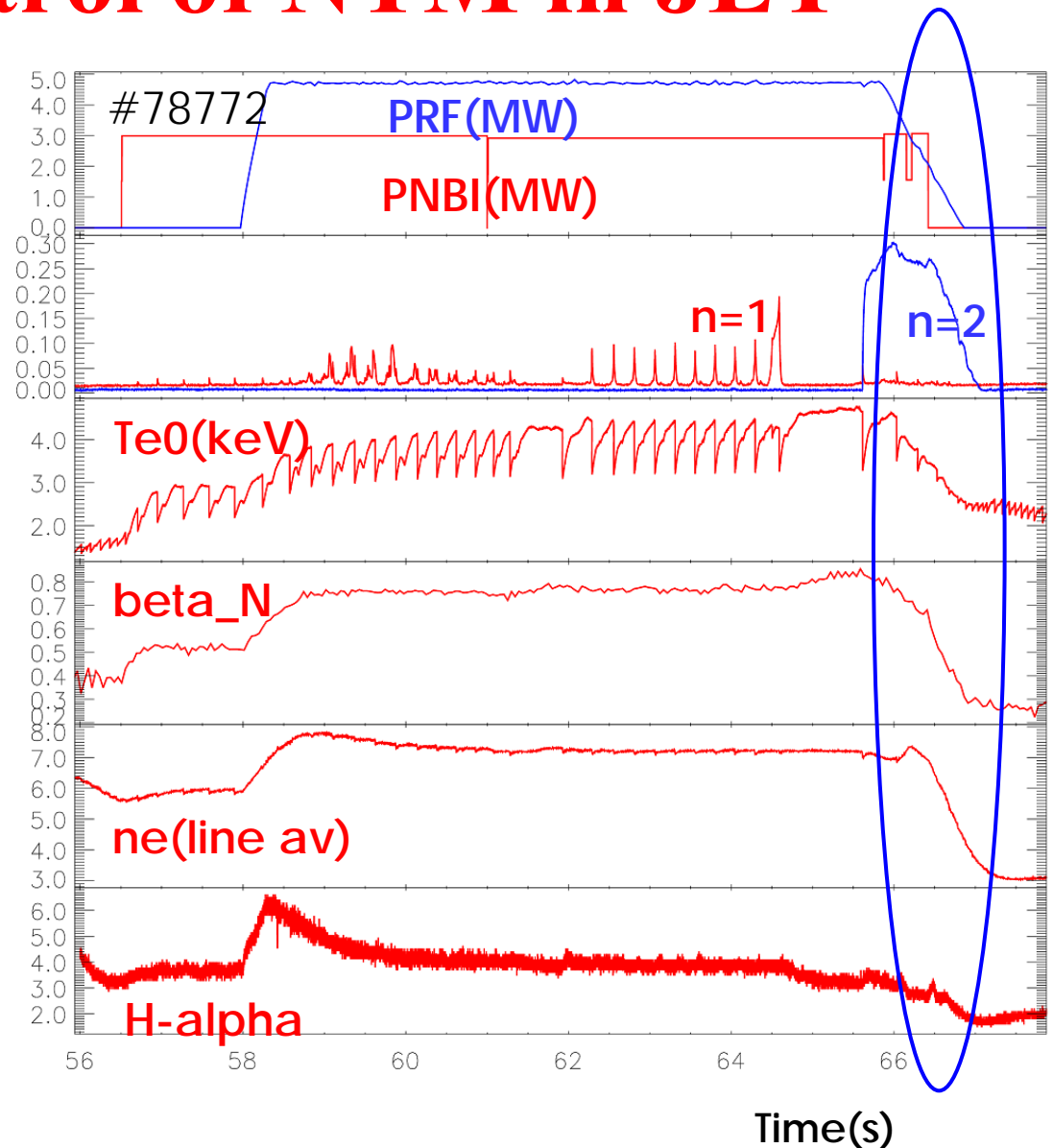

J. P. Graves, in preparation for publication (2010)

J. P. Graves, IISS, Austin, 31 May – 4 June 2010





Growth Rate of Sawtooth Triggered NTM

The $n=2$ mode could be saturated within the crash time (about 10 micro-seconds), and certainly within 100 micro-seconds.

Much faster than reaction time of ECRH controller on NTM 3/2 surf.

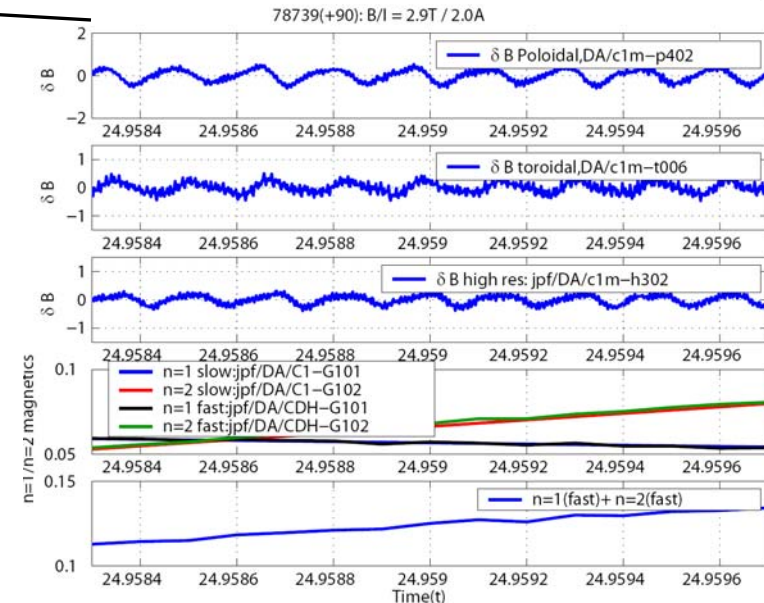
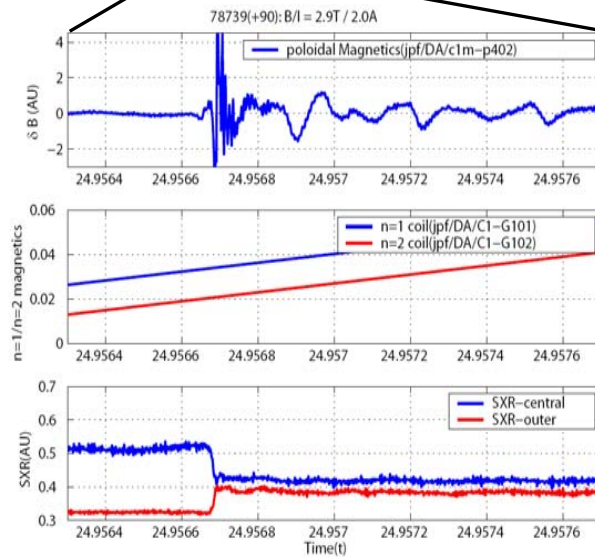
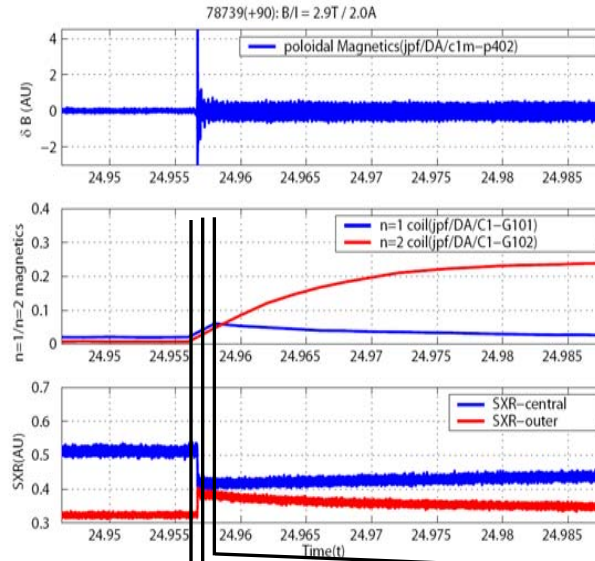



Link Between Sawteeth and NTMs

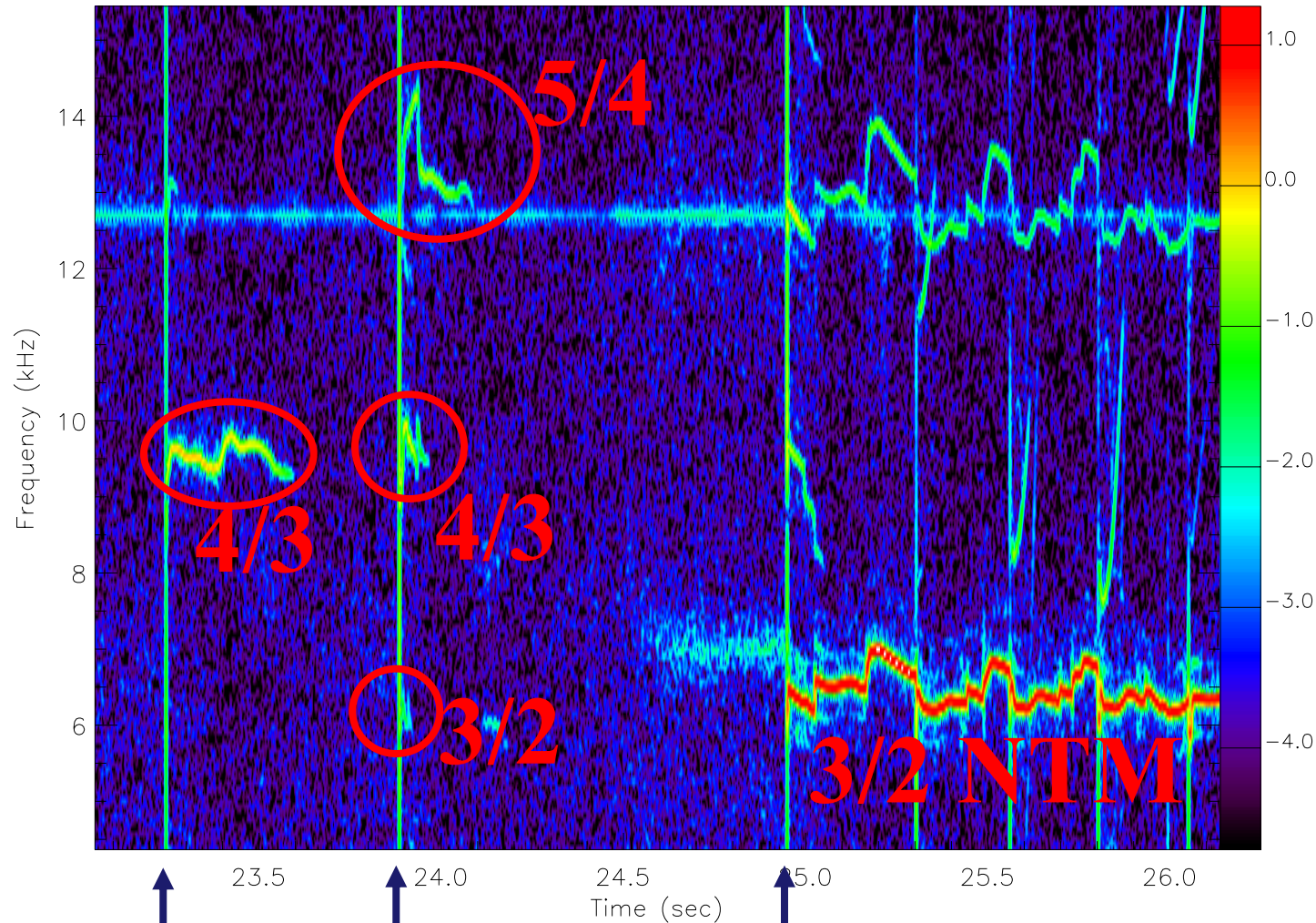

sawteeth



J. P. Graves, IISS, Austin, 31 May – 4 June 2010



Link Between Sawteeth and NTMs

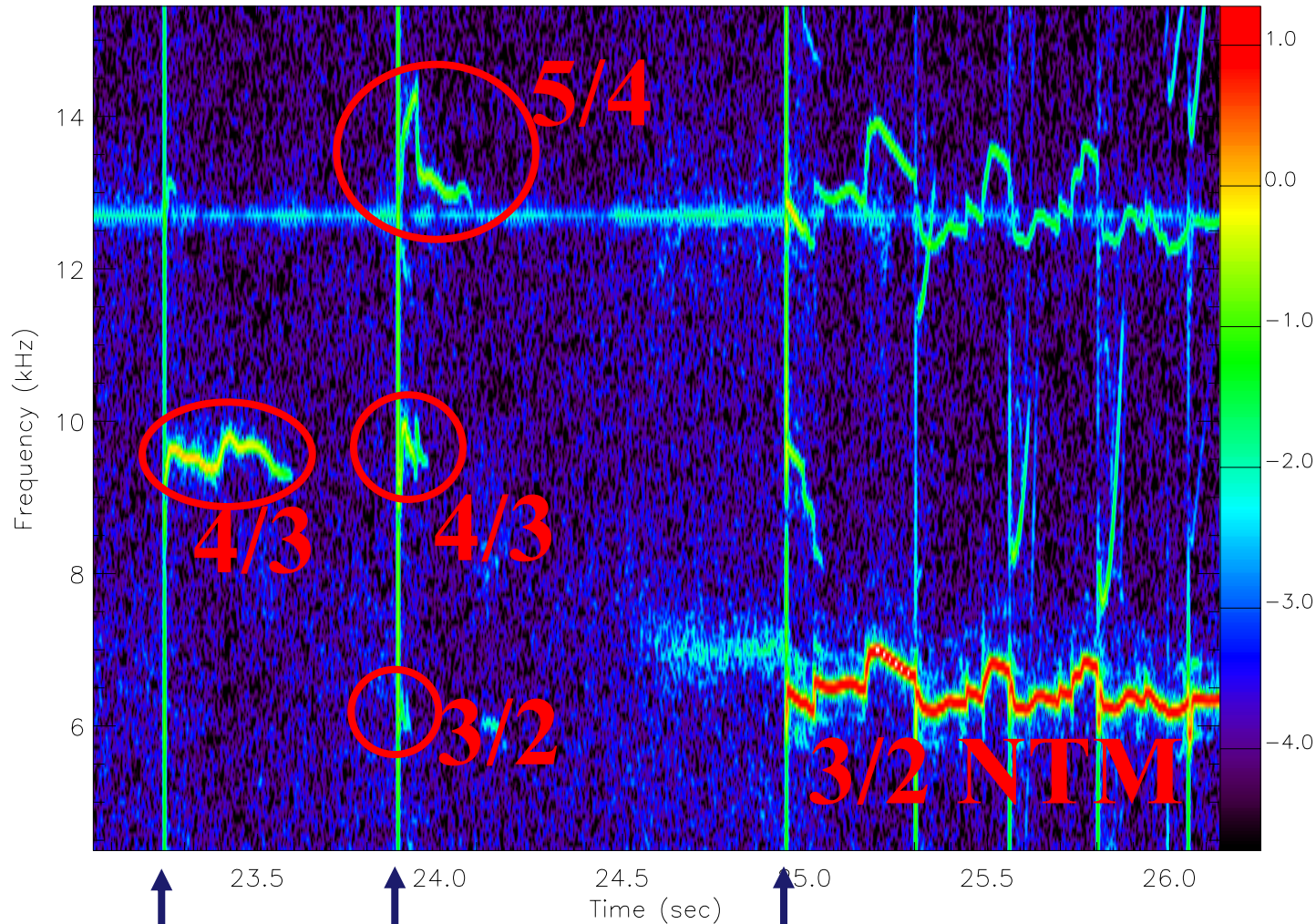

Long period sawtooth triggers saturated NTM [this was initially suggested by Cambell PRL 1988, and Sauter PRL 2002]

sawteeth



J. P. Graves, IISS, Austin, 31 May – 4 June 2010



Motivation – ITER

- Why is this a problem for ITER?

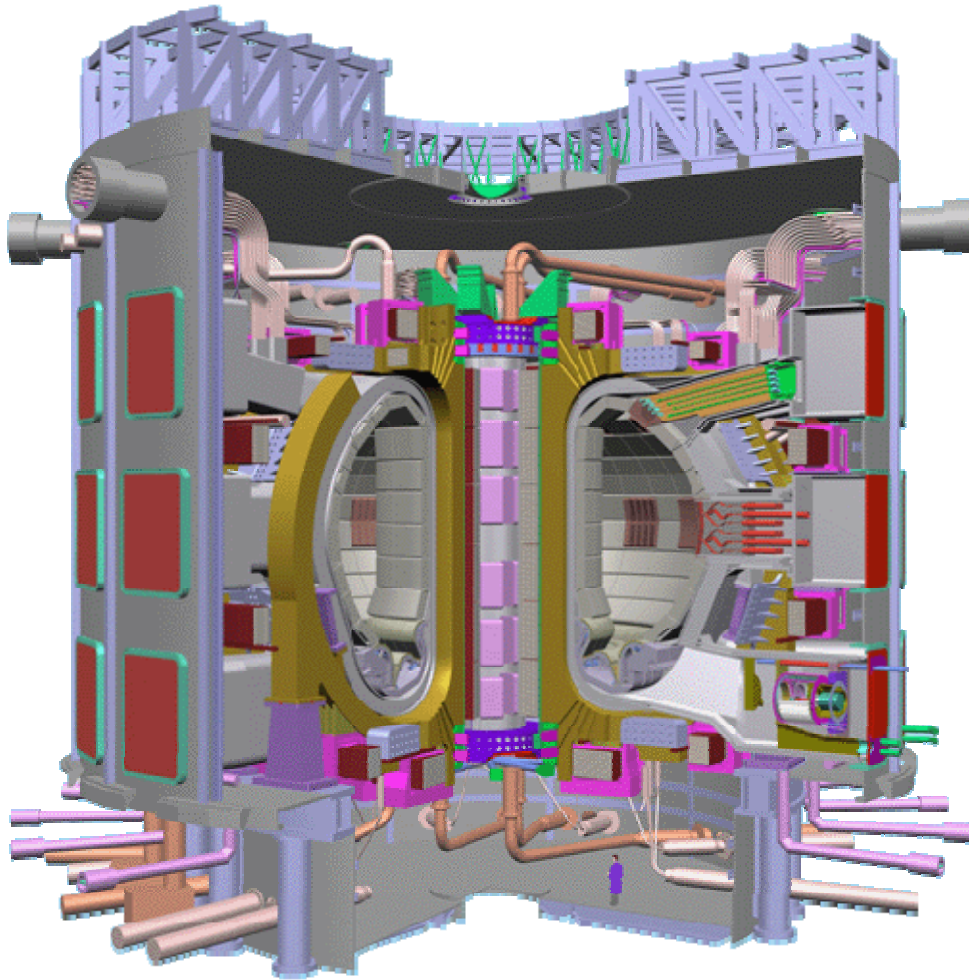

ITER will have large fusion-born alpha particle population in the core



Long sawtooth periods



Trigger NTMs and cause confinement degradation (reduced fusion power... etc), or worse disruption



Since NTMs can be at large amplitude very rapidly, a prevention approach recommended: keep sawteeth small and frequent

J. P. Graves, IISS, Austin, 31 May – 4 June 2010



The Sawtooth Trigger

Well known simple sawtooth triggering criteria [F. Porcelli PPCF, (1996)]:

1. Resistive two-fluid instability: $\pi \frac{\delta \hat{W}}{s_1} < \hat{\rho}$ and $s_1 > s_c(\beta)$
2. Ideal Instability: $\pi \frac{\delta \hat{W}}{s_1} < -\frac{\omega_{*i} \tau_A}{2}$

δW is the energy associated with the ideal internal kink mode. Fast trapped ions, such as those from ICRH or fusion alphas, can yield a large, stabilising (positive) contribution.

The standard means of early crash triggering is to attempt to deliberately increase the magnetic shear at the $q=1$ surface, s_1



How does driving current trigger sawteeth?

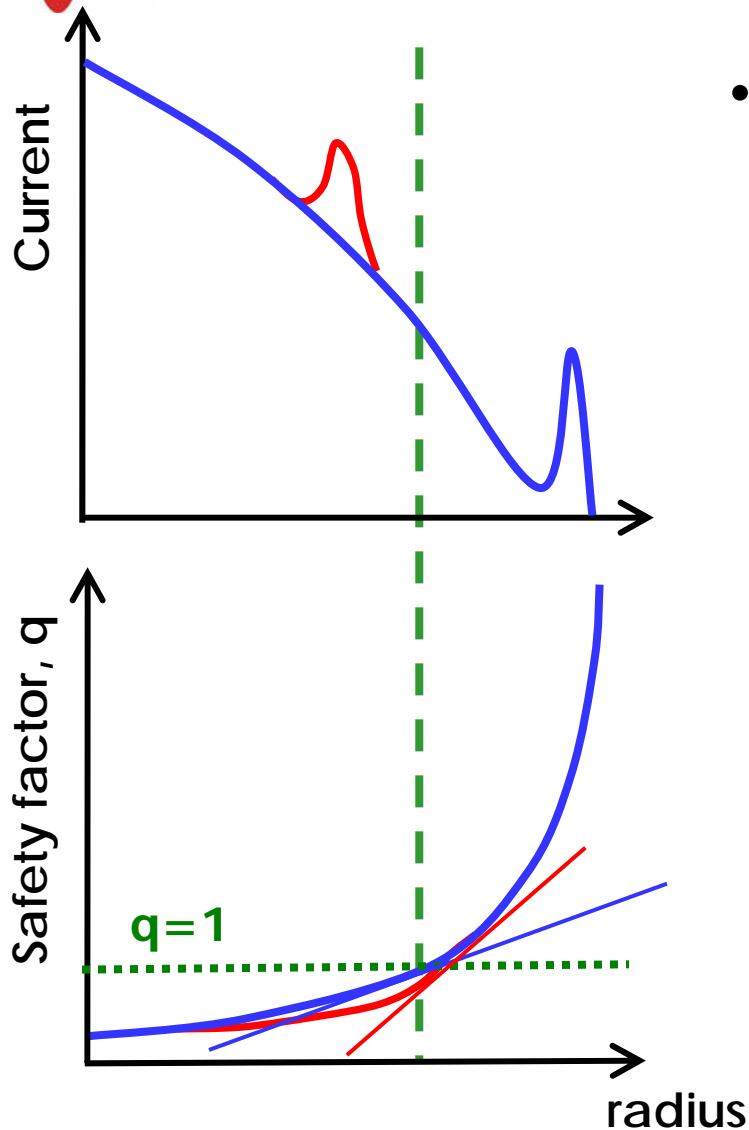

- Trigger condition: $\pi \frac{\delta \hat{W}}{s_1} < c_\rho \frac{\rho}{r_1}$

A perturbation is applied to the initial current profile (inside $q=1$)



More current means more poloidal field, so q drops



$q=1$ is moved outwards



Magnetic shear at $q=1$, s_1 (\sim gradient of q) increases



TCV EC Systems

- Electron cyclotron heating & current drive systems are a useful tool for controlling the sawtooth period.
 - ❖ Modify the local current profile.
- TCV has a 3 MW X2 EC system
 - ❖ 6 gyrotrons, 6 launchers real time control of power and 'poloidal' angle
- 1 launcher (500kw) used in these experiments
 - ❖ Toroidal angle set to generate co-ECCD/ECRH
 - ❖ A motor adjusts the launcher poloidal angle.

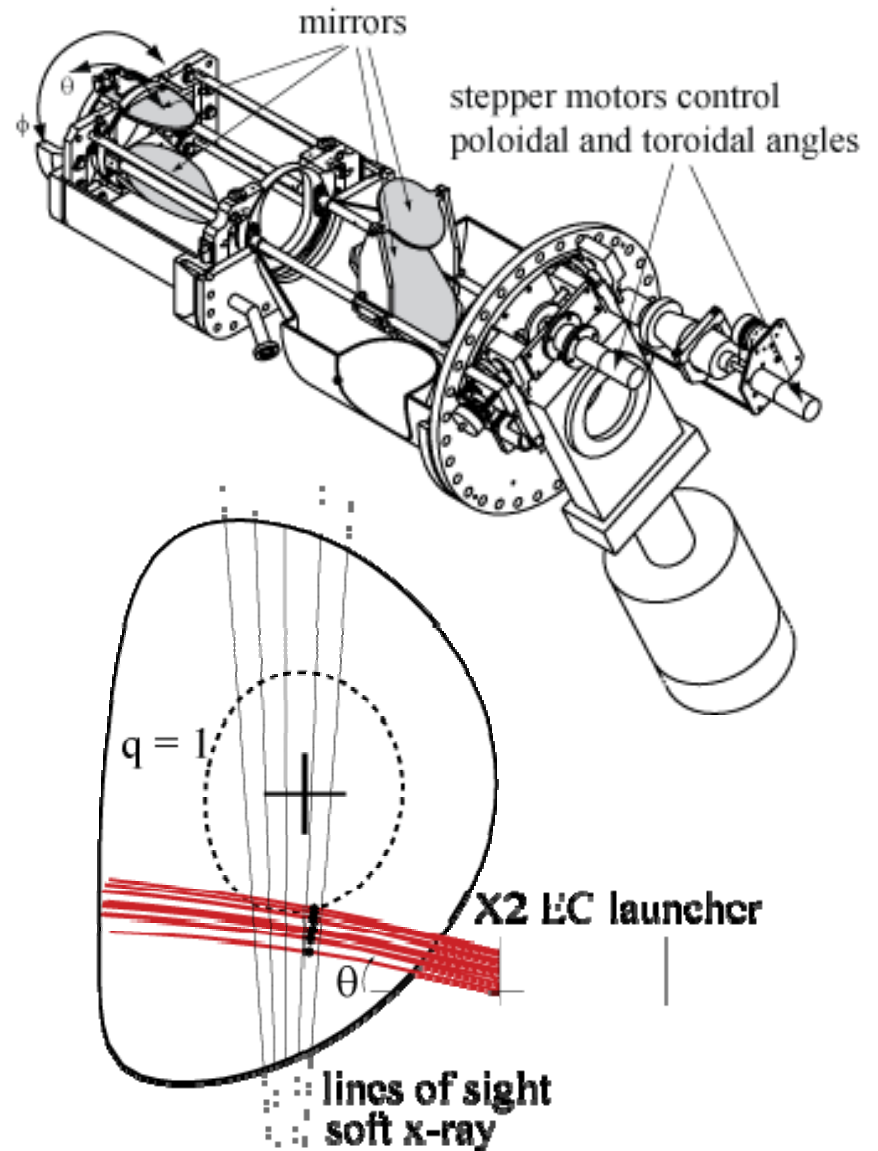



Real-time control via ECCD in TCV

- Sweep EC deposition in vicinity of $q = 1$, in both directions. Generate shear modification by ECH (as before) and with electron cyclotron current drive (ECCD)
- Peak shifts due to movement of $q=1$ surface
- Used to build a control model of the plasma response
 - ❖ angle vs period lookup table
 - ❖ also includes shift in peak due to launcher position history.

[J. I. Paley et al, Plasma Phys. Control. Fusion 51, 124041 (2009)]

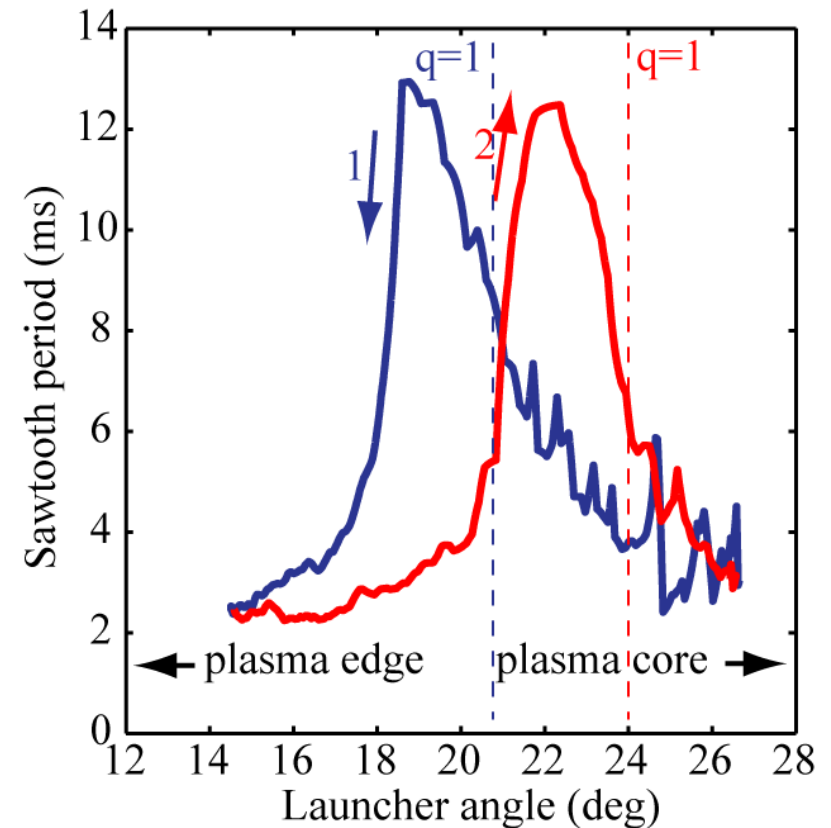

With co-current ECCD/ECHR, peak in the period when deposition is just outside the $q=1$ surface.



Real-time control via ECCD in TCV

- Deposit EC outside the peak in the period.
 - ❖ If period $<$ ref, increase angle
 - ❖ If period $>$ ref, decrease angle
- Ensure target period is $<$ maximum
- Ensure controller gains are not too large.
 - ❖ Overshoot could lead to an unstable system.

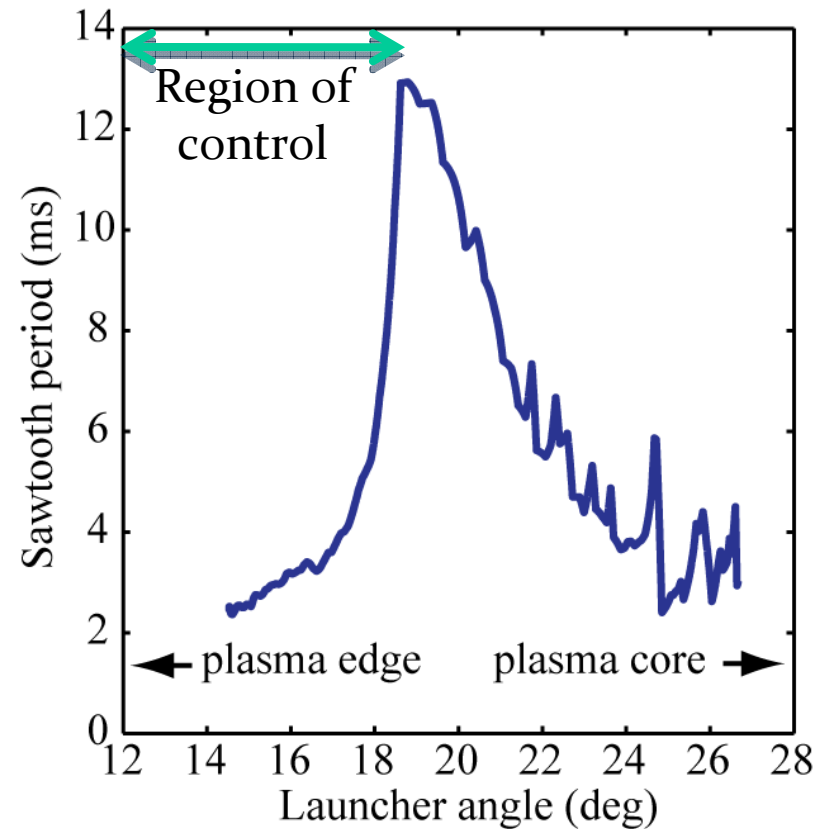

[J. I. Paley et al, Plasma Phys. Control. Fusion 51, 124041 (2009)]

J. P. Graves, IISS, Austin, 31 May – 4 June 2010



Real-time control via ECCD in TCV

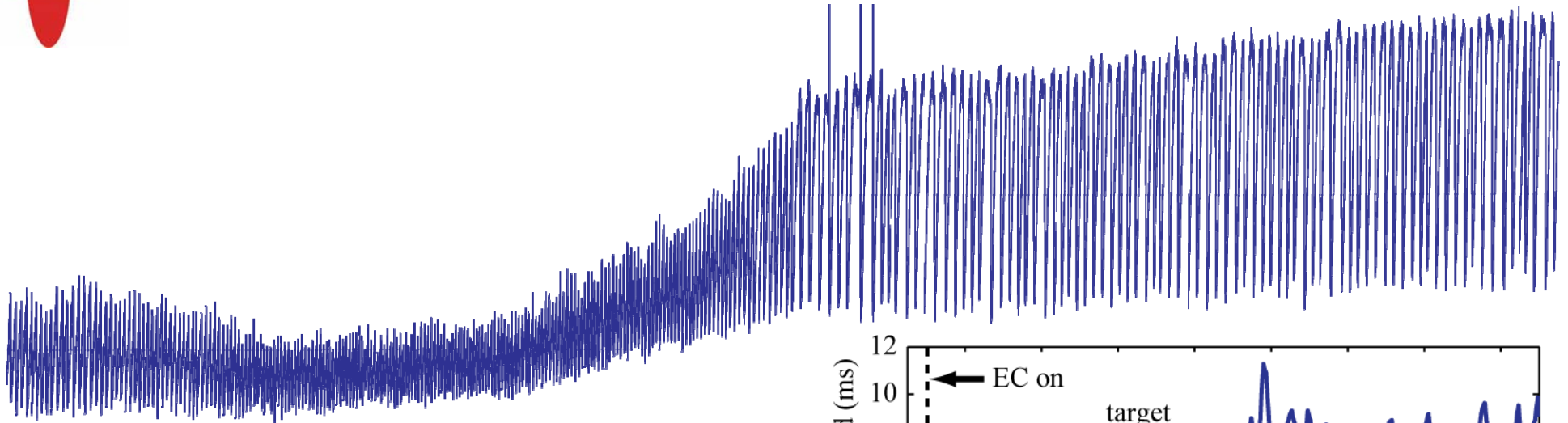

- Drive the launcher at two speeds:
 - ❖ Fast (20deg/s) if:
 - Target < 4ms
 - Target > 4ms & observed period < 4ms
 - ❖ Slow (2deg/s) if:
 - target and observed > 4ms

[J. I. Paley et al, Plasma Phys. Control. Fusion 51, 124041 (2009)]

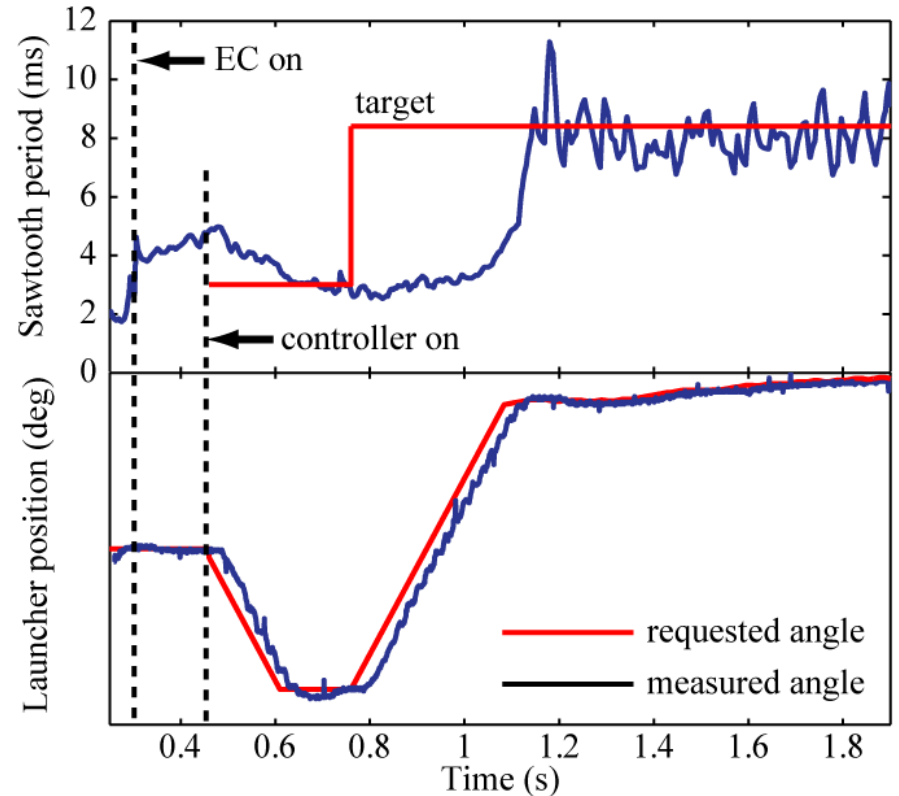



Tore Supra: Feedback control

- Tore-Supra has both ICRH and ECRH systems.
- ICRH can be employed to initially lengthen sawteeth, and in this way, the RF ions simulate the expected role of fusion alpha particles.
- Since the sawteeth are initially much longer than Ohmic sawteeth, one can employ ECCD, or ECH, to reduce the sawtooth period (the opposite to the real-time TCV pulses shown earlier).
- This work has recently been published by M. Lennholm et al, PRL 2009.



ECRH on Tore Supra

Toroidal angle +/-28°

Only top Mirror Used

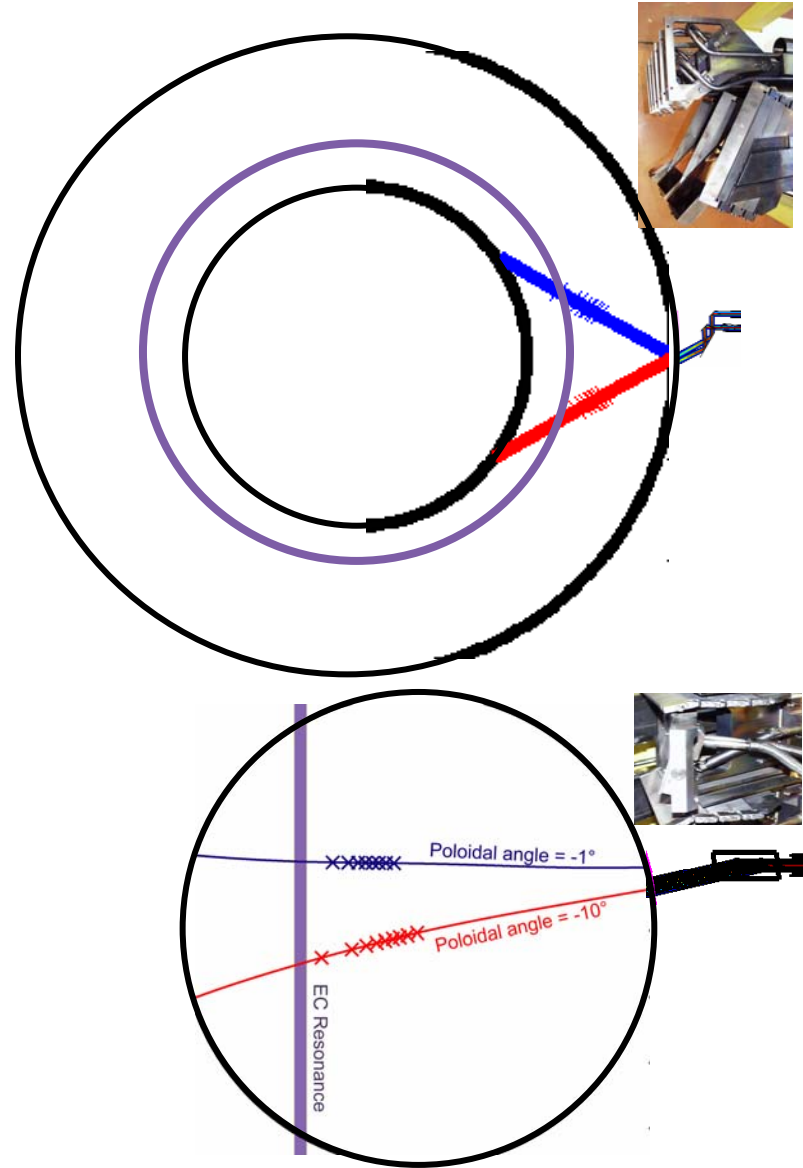
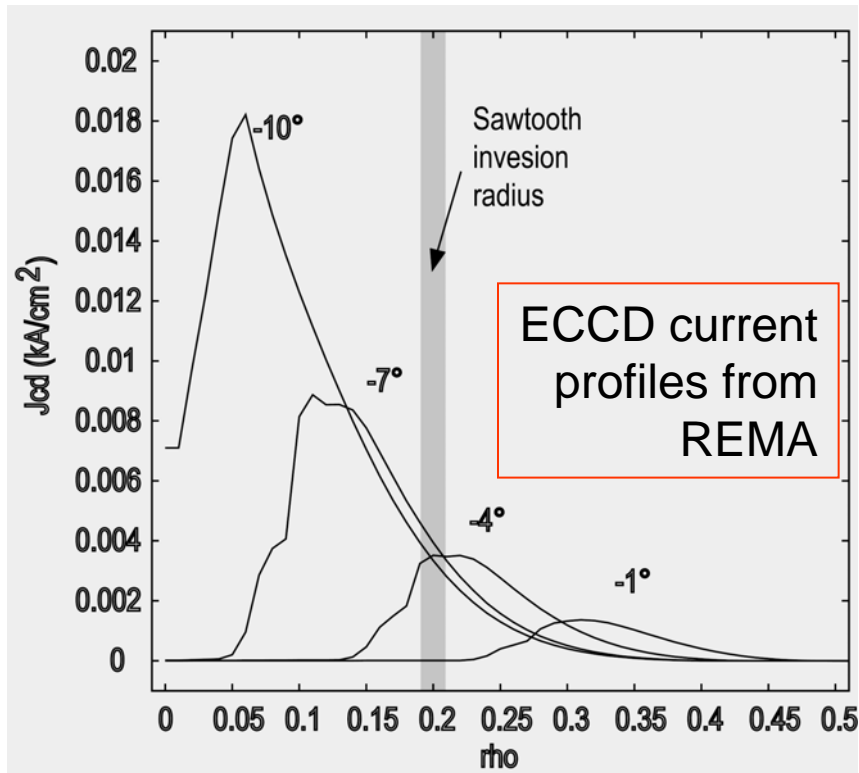



Tore Supra: Feedback control

- Determine plasma response
- Implement real Time:
 - Sawtooth period detection
 - Injection angle control
 - Communication
 - Control algorithms

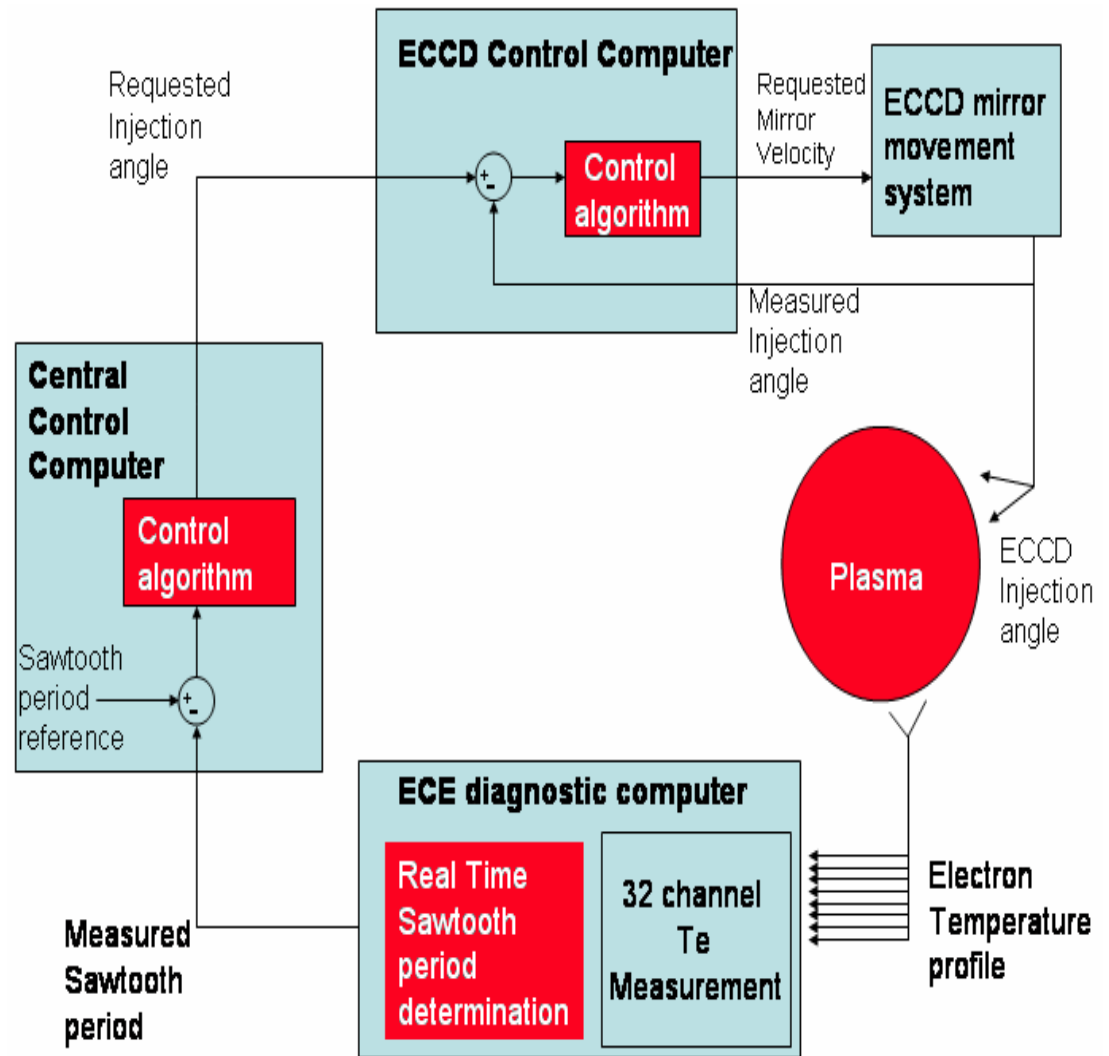



Tore Supra: Feedback control

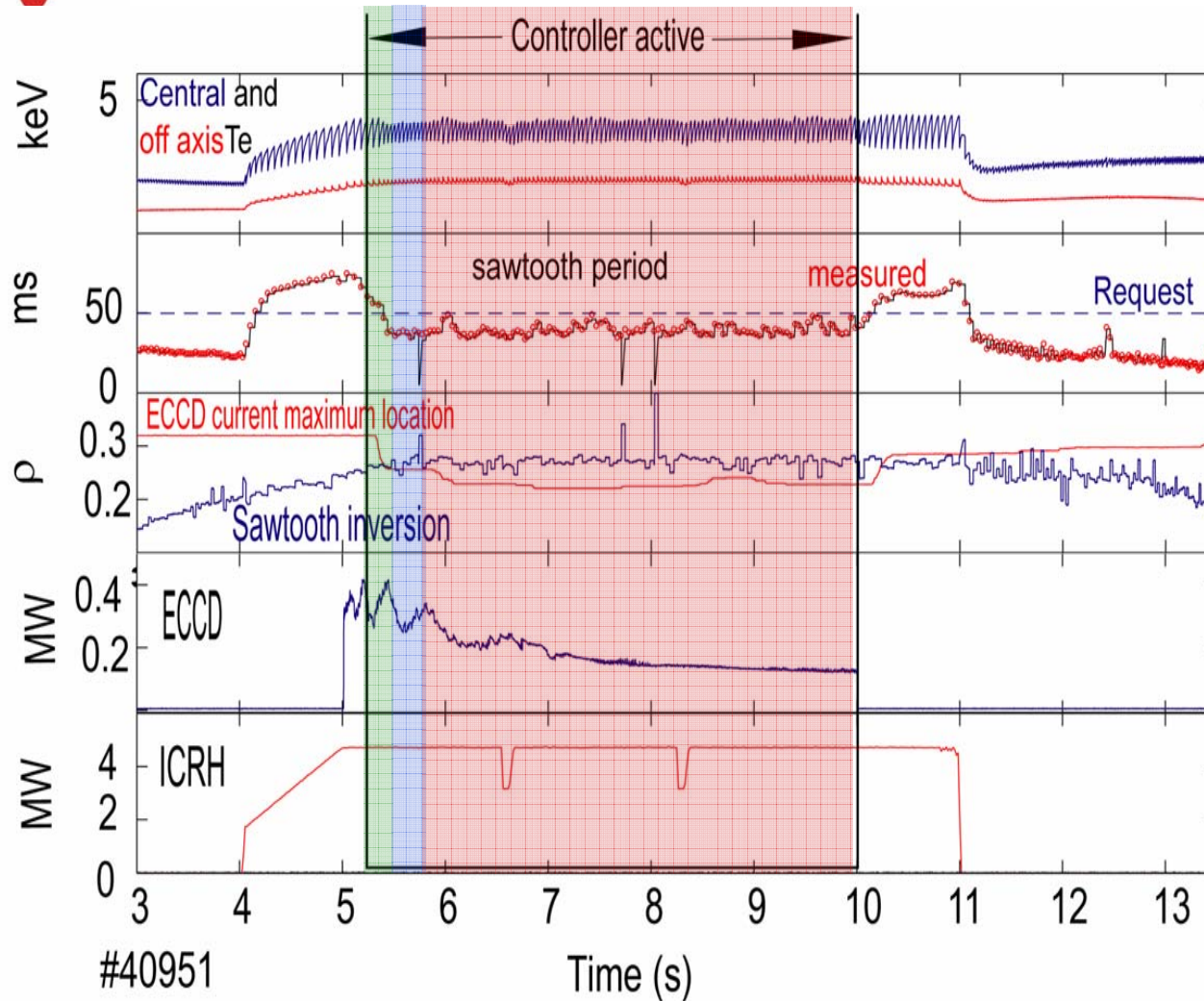

1: Controller moves mirror until measured Sawtooth period < request

2: Distance (d_0) between Inversion Radius and ECCD location at this moment noted

3: Feedback control keeping the Distance between the measured sawtooth inversion radius and the ECCD location = $d_0 + 2\text{cm}$

M. Lennholm et al, PRL 2009

J. P. Graves, IISS, Austin, 31 May – 4 June 2010



ITER ECH/ECCD Design

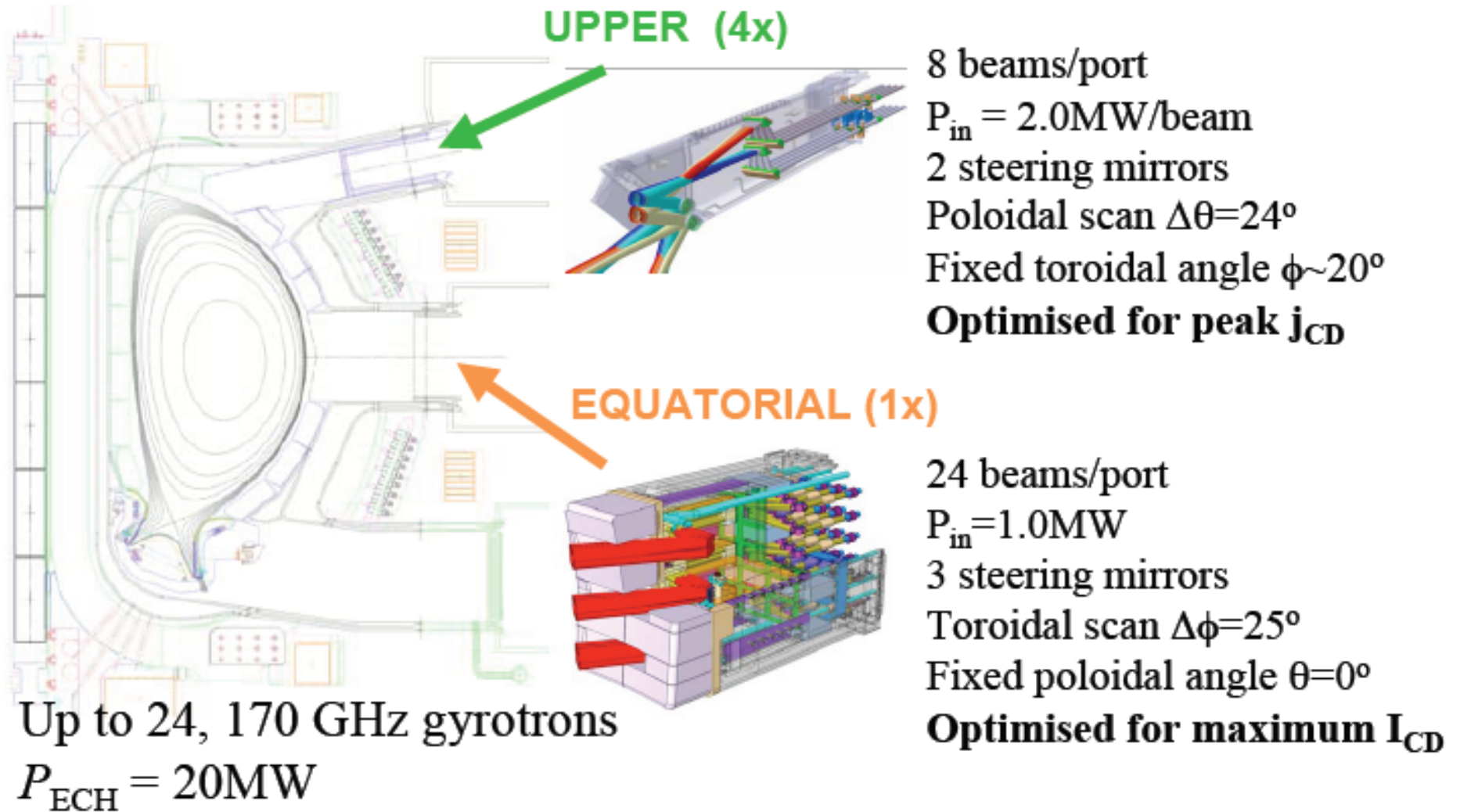



ITER ECH Launcher Functionality

Upper Launcher

Advanced design:

- *Deposition:* $0.3 \leq \rho_T \leq 0.95$
- NTM stabilisation & Sawtooth control

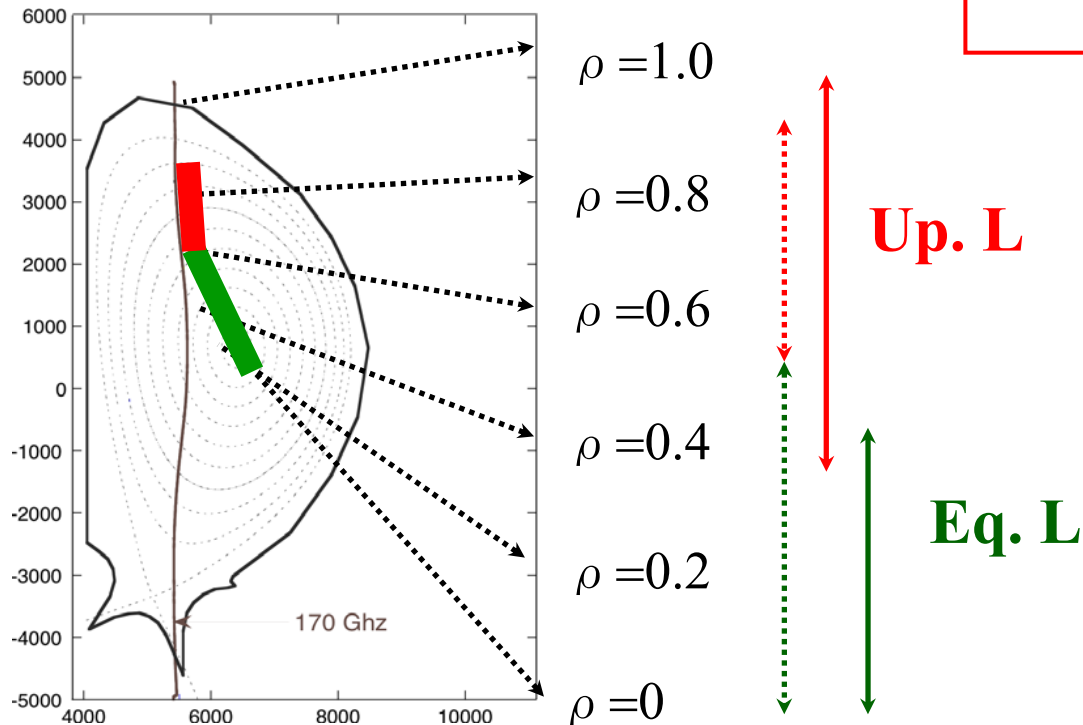



ECCD and ITER Scenarios

AIM:

- To analyse capabilities in controlling ST period by optimized UL
- To provide potential range of the q profile control achievable by this EC system optimization.

- 3 selected full-field H-mode scenarios at EOB:

- Scen 2 (standard, 15 MA)
- Scen 3a (hybrid, 12 MA)
- Scen 4 (RS, 9 MA)

- Different q , T , n , BS profiles.

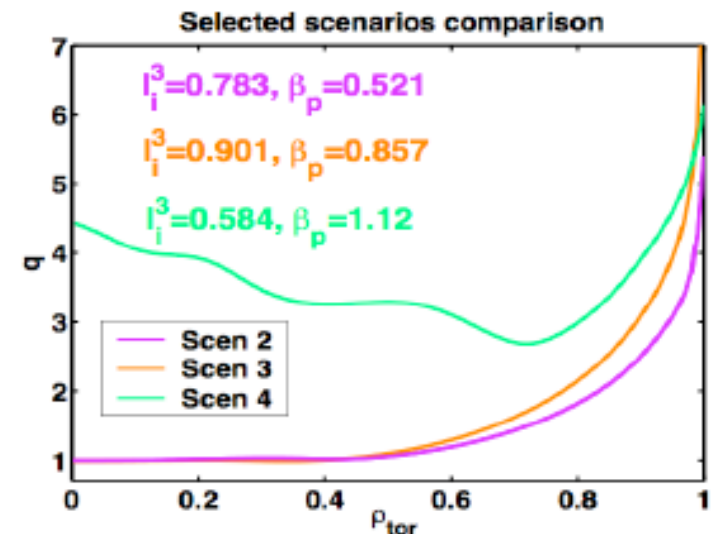
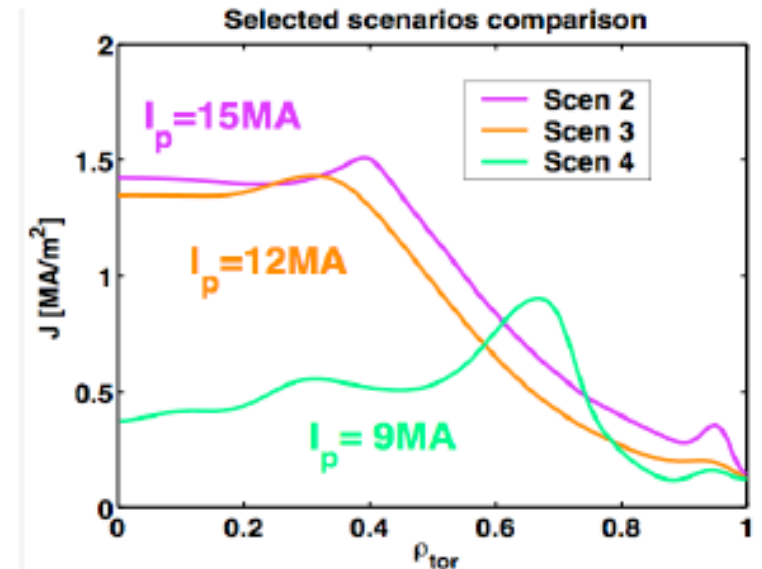



Shear Modification with ITER UL

Hybrid Scenario 3a ($I_p=12\text{MA}$)

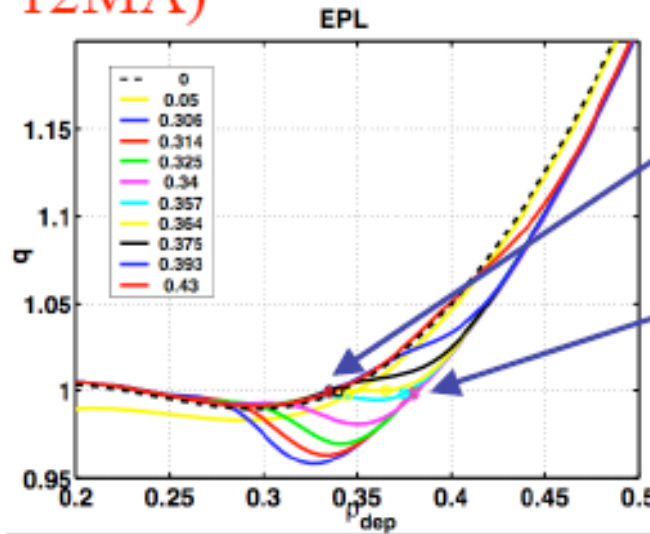
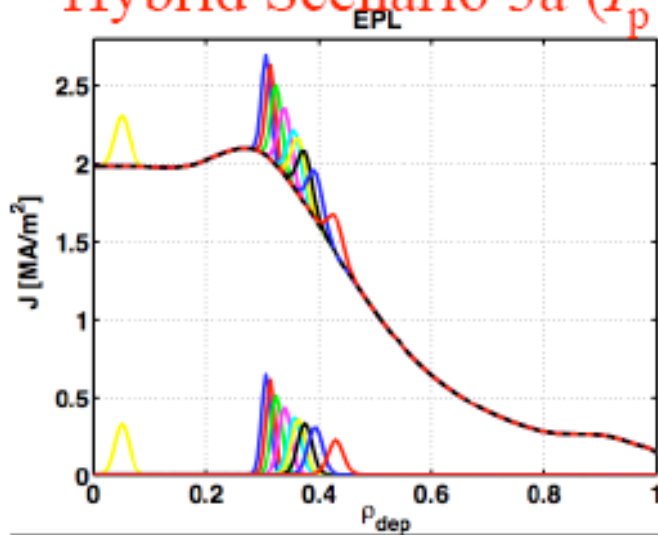

co-ECCD
at various ρ_{dep}
around $q=1$
($I_{\text{cd}} = 130\text{-}140\text{kA}$)

$$\Delta\alpha = 66\text{-}69^\circ$$

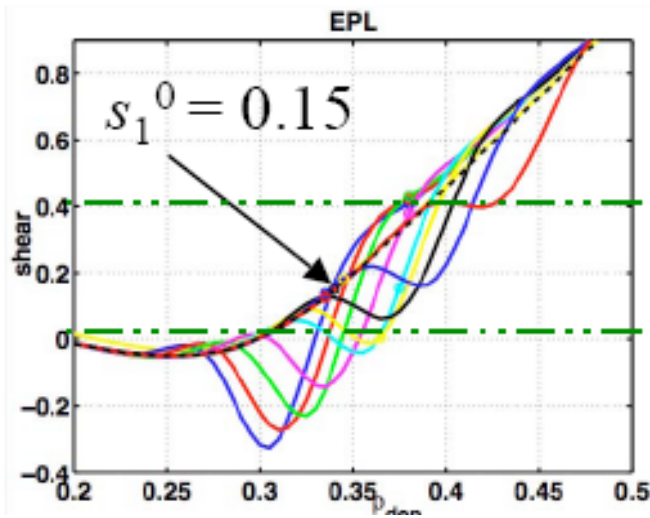

- Deposition of co-ECCD inside or outside inversion radius allows changing s_1 by large range ($s_1 \sim 0\text{-}0.4$). [Zucca *et al*].
- Stabilise sawteeth with $s_1 < 0.2$ or at least significantly delay 1st sawtooth?



Sawtooth Control in Fusion Grade Plasmas

Let us return to the standard sawtooth trigger model:

1. Resistive two-fluid instability:
$$\pi \frac{\delta \hat{W}}{s_1} < c_\rho \frac{\rho}{r_1}$$

We have seen that sawteeth can be controlled via modifying s_1 in TCV and TORE-SUPRA

There are two obvious issues to be addressed however:

- 1) In ITER, alpha contribution to δW expected to be large and stabilising, and $\hat{\rho}$ small. Control via shear modification might be difficult.
- 2) Sawteeth in JET are controlled with very modest current drive perturbations.



Effect of Passing Energetic Ions on δW

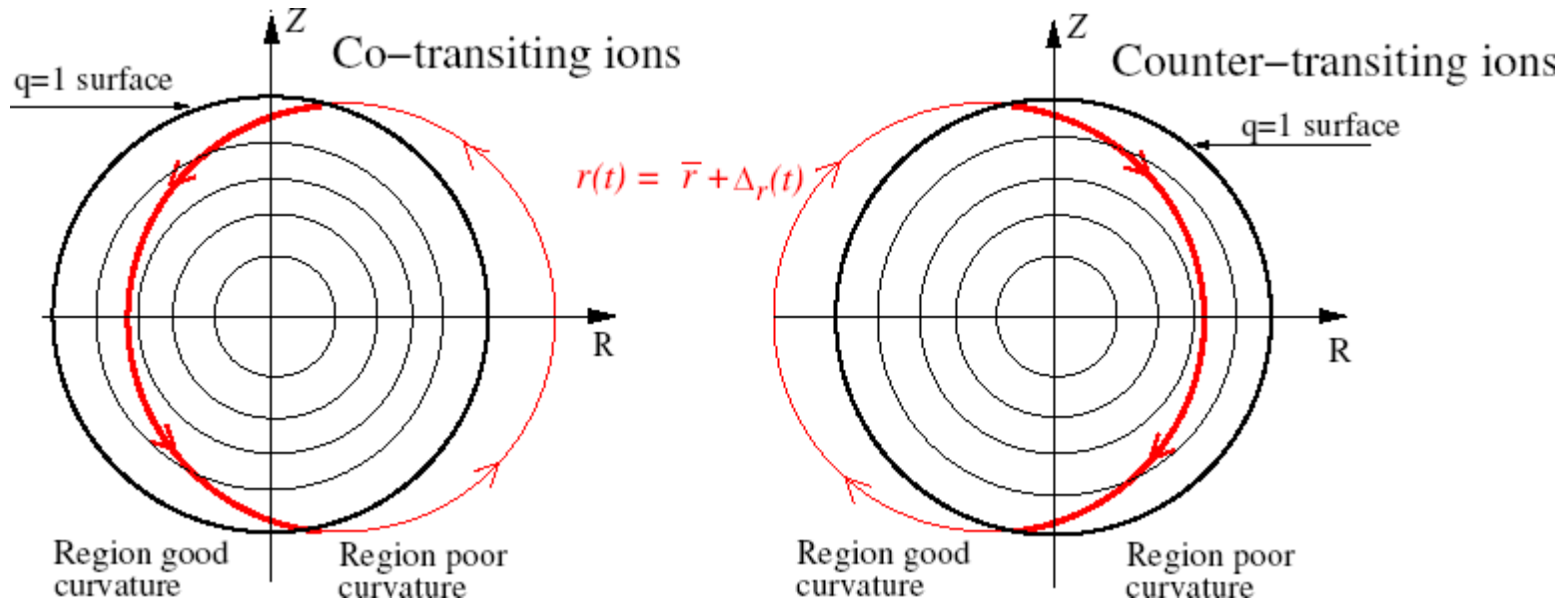

[Graves, PRL, 92, 2004]

- Only get net effect on stability when distribution asymmetric:

$$F_h(v_{\parallel}^+) \neq F_h(v_{\parallel}^-)$$

- Effect increasingly strong for increasing Δ_r (increasing fast ion energy)

- Destabilisation for: $F_h(v_{\parallel}^+) > F_h(v_{\parallel}^-)$ and $\nabla F_h|_{r_1} > 0$

or: $F_h(v_{\parallel}^+) < F_h(v_{\parallel}^-)$ and $\nabla F_h|_{r_1} < 0$

J. P. Graves, IISS, Austin, 31 May – 4 June 2010



Sawtooth Control using co-current NBI in JET

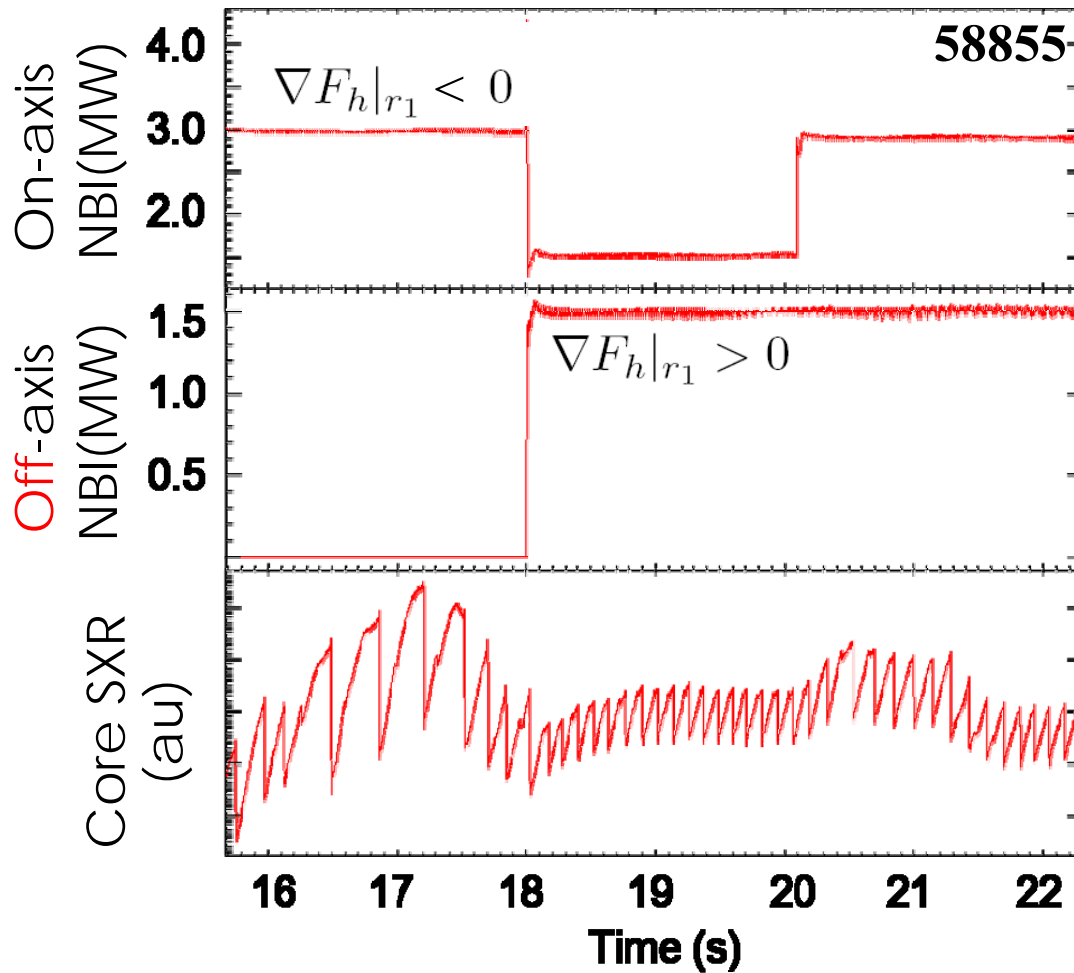

Co-NNBI gives:

$$F_h(v_{\parallel}^+) > F_h(v_{\parallel}^-)$$

so destabilisation only with off-axis:

$$\nabla F_h|_{r_1} > 0$$

Modelling shows fast ion effects dominate and NBCD effect is very small.

[Chapman et al, Nucl Fus 49 2009]



J. P. Graves, IISS, Austin, 31 May – 4 June 2010



Orbit Width Effect and NBI, NNBI, ICRH

Effect of fast asymmetric passing ions become more significant with increasing effective orbit width:

$$\overline{\Delta_r} = \left(\frac{v_{\parallel}^2(\theta = 0)}{(2\mathcal{E})^{3/2}} \right) \frac{1}{2\pi} \int_0^{2\pi} d\theta \left(\frac{R_0}{R} \right) \left[\frac{v_{\parallel}^2 + v_{\perp}^2/2}{v_{\parallel}} \right] \Delta_r$$

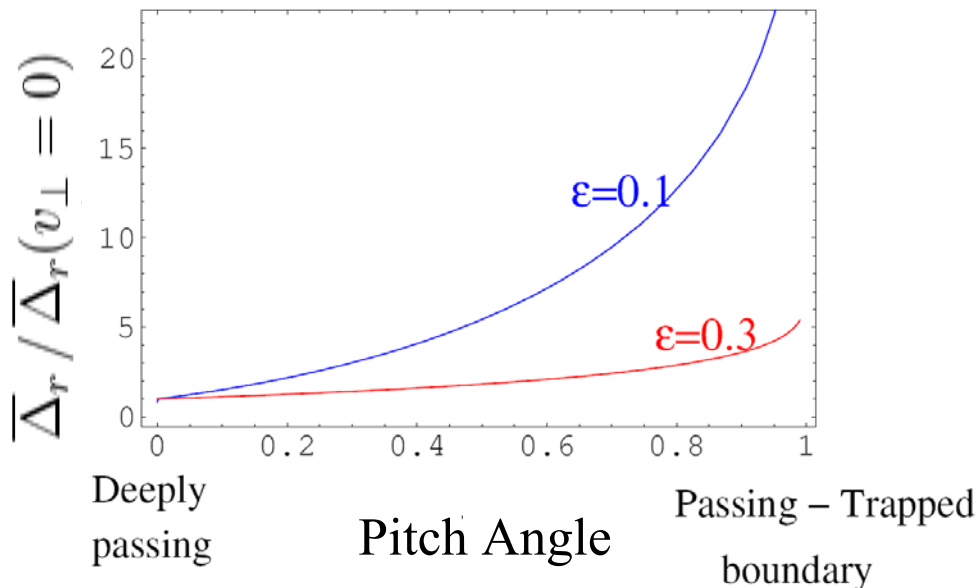

Two ways to enhance effective orbit width:

1. Large thermal velocity (NNBI in JT-60U and ITER).
2. Large fraction of barely passing ions (NBI in JET and MAST and others).

Both 1. and 2. are satisfied with ICRH



Asymmetry in counter current ICRF pulses

- Parallel velocity asymmetry in F_h seen for trapped and passing ions

Excess of counter-passing ions

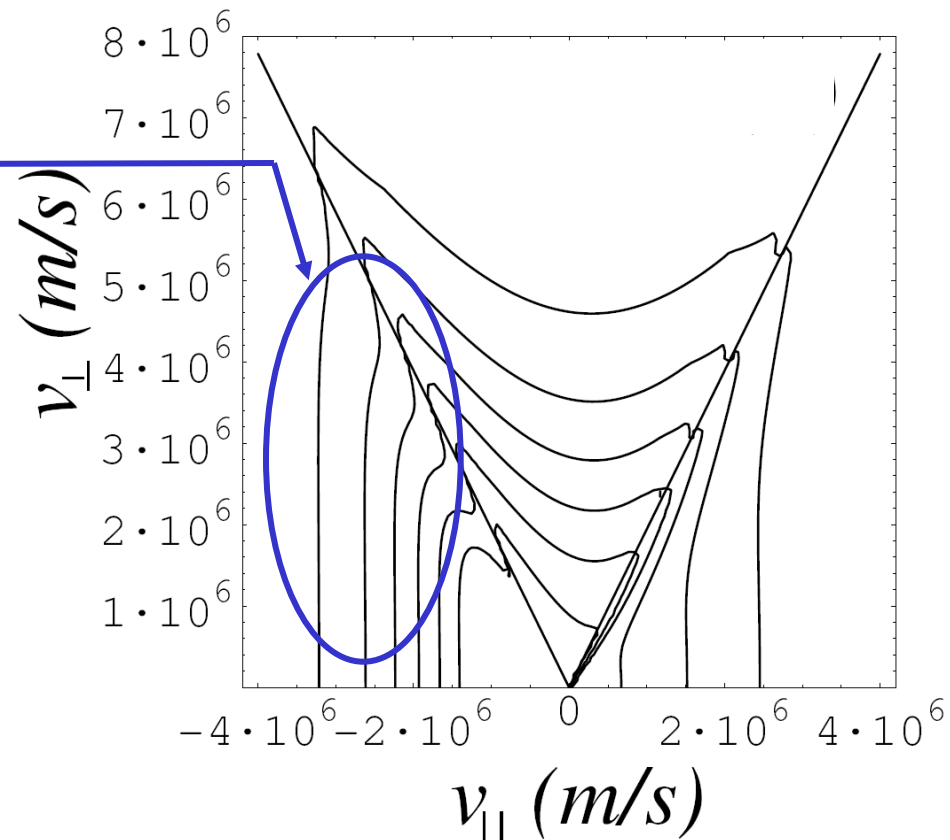



Asymmetry in RF counter-ICRF Pulses

- The internal kink theory extended, accounting for more general distribution function, including one applicable for toroidally propagating ICRF waves [Graves, PRL 2009].
- Parallel velocity asymmetry in F_h seen in the ICRH current [SELFO code, Hedin et al]

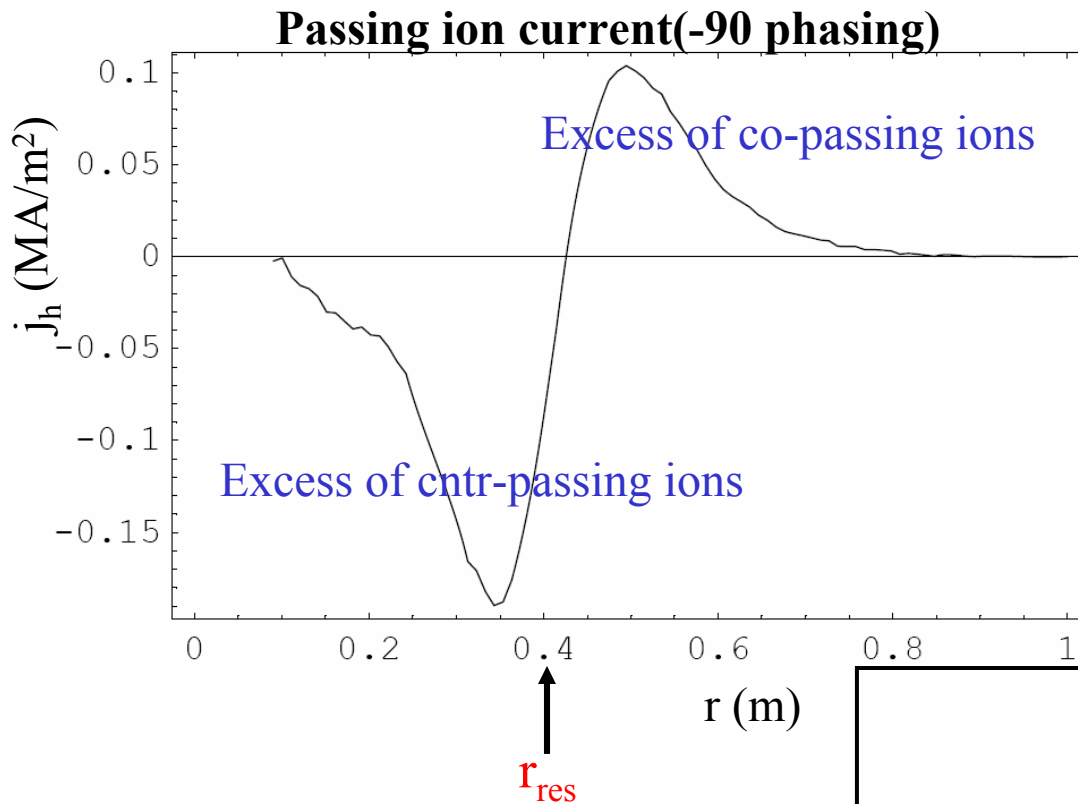

$$j_{\phi}(r) \approx eZ_h \int dv^3 \sum_{\sigma} v_{\parallel} F_h$$





Asymmetry in RF counter-ICRF Pulses

- The internal kink theory extended, accounting for more general distribution function, including one applicable for toroidally propagating ICRF waves [Graves, PRL 2009].
- Parallel velocity asymmetry in F_h seen in the ICRH current [SELFO code, Hedin et al]

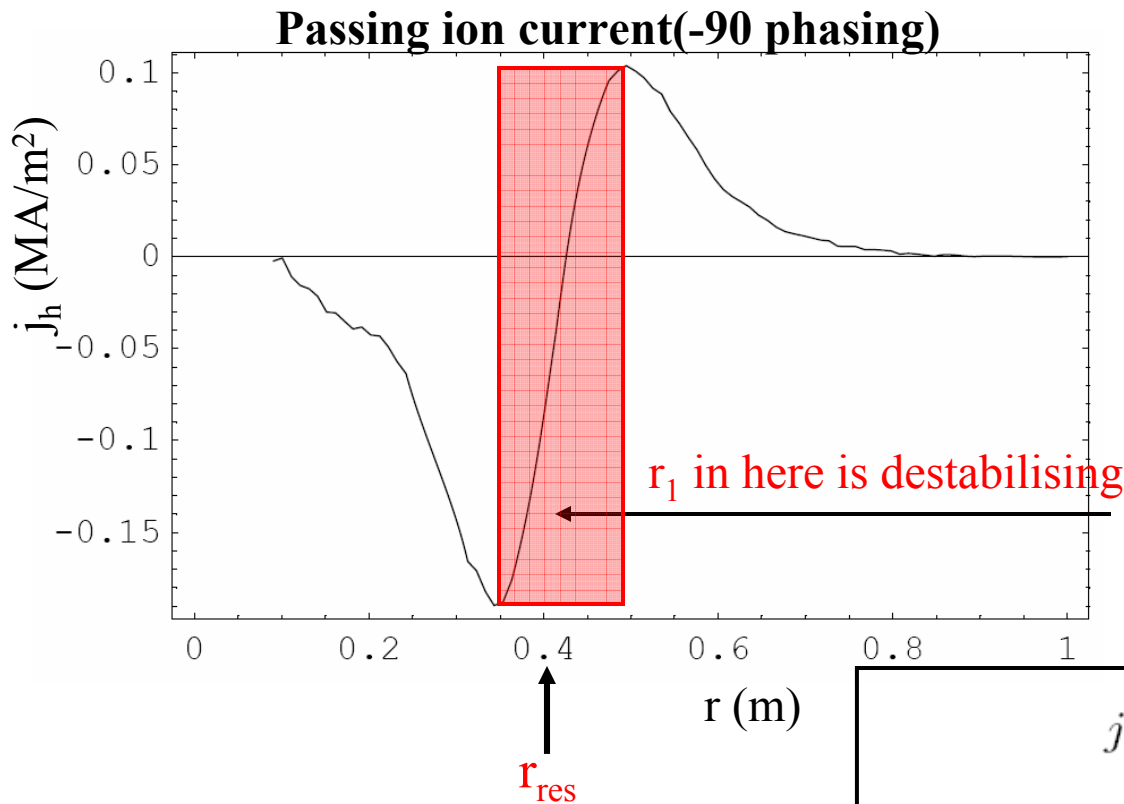

$$j_\phi(r) \approx eZ_h \int dv^3 \sum_\sigma v_\parallel F_h$$

$$\delta W \propto - \int dv^3 \sum_\sigma \left(\frac{v_\perp^2}{2} + v_\parallel^2 \right) \Delta_r \frac{\partial F_h}{\partial r} \Big|_{r_1} \sim - T_h \frac{dj_\phi}{dr} \Big|_{r_1}$$

J. P. Graves, IISS, Austin, 31 May – 4 June 2010





Asymmetry in RF counter-ICRF Pulses

- The internal kink theory extended, accounting for more general distribution function, including one applicable for toroidally propagating ICRF waves [Graves, PRL 2009].
- Parallel velocity asymmetry in F_h seen in the ICRH current [SELFO code, Hedin et al]

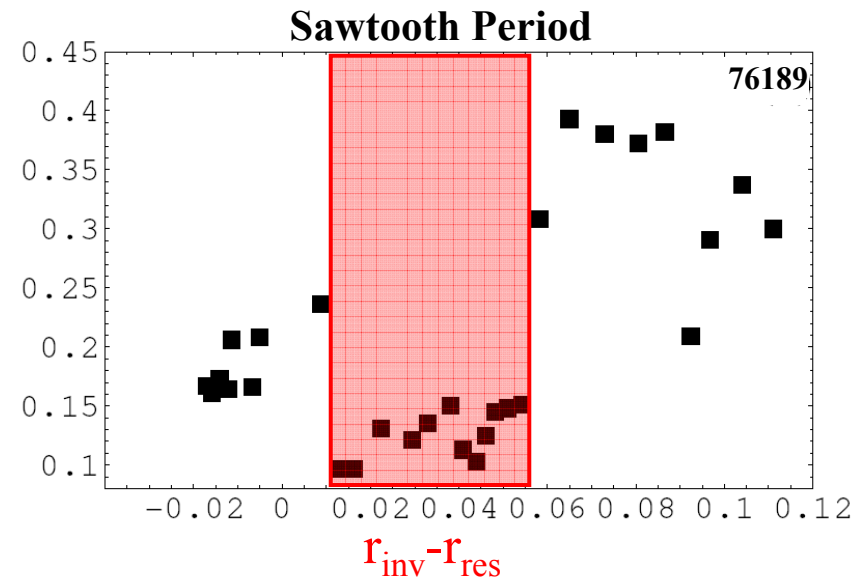
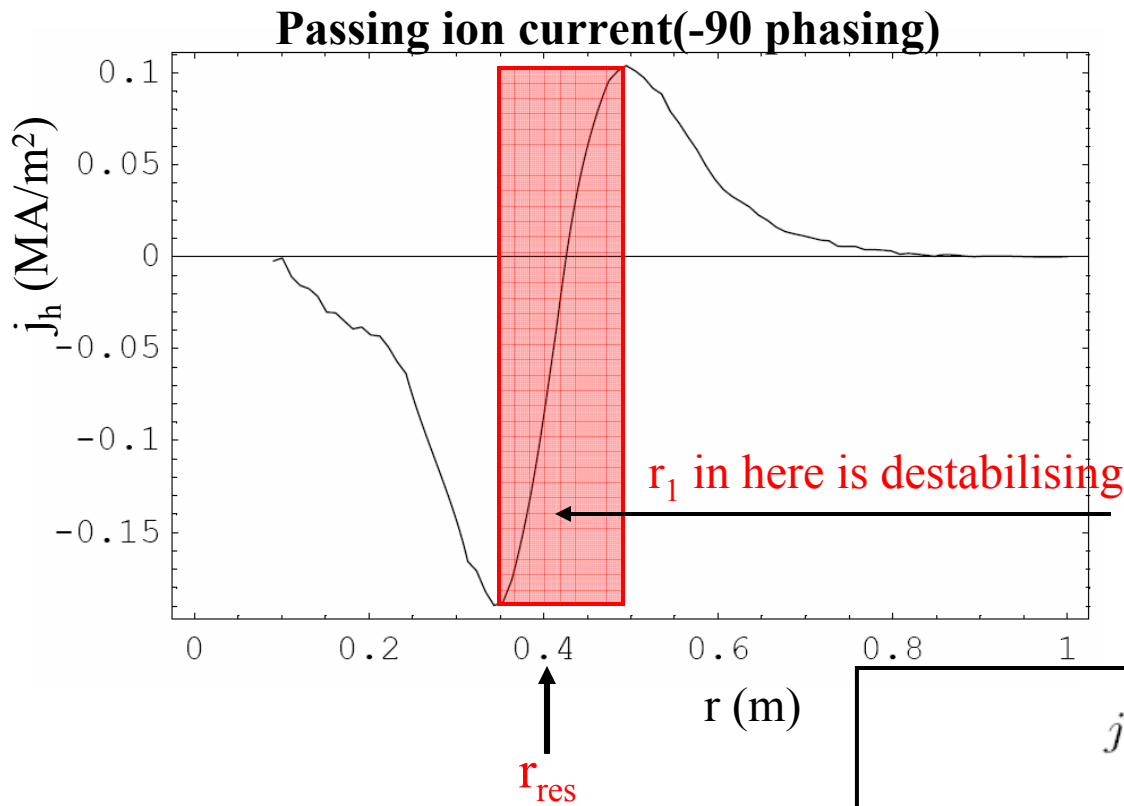

$$j_\phi(r) \approx eZ_h \int dv^3 \sum_\sigma v_\parallel F_h$$

$$\delta W \propto - \int dv^3 \sum_\sigma \left(\frac{v_\perp^2}{2} + v_\parallel^2 \right) \Delta_r \frac{\partial F_h}{\partial r} \Big|_{r_1} \sim - T_h \frac{dj_\phi}{dr} \Big|_{r_1}$$

J. P. Graves, IISS, Austin, 31 May – 4 June 2010





JET Experimental Configuration

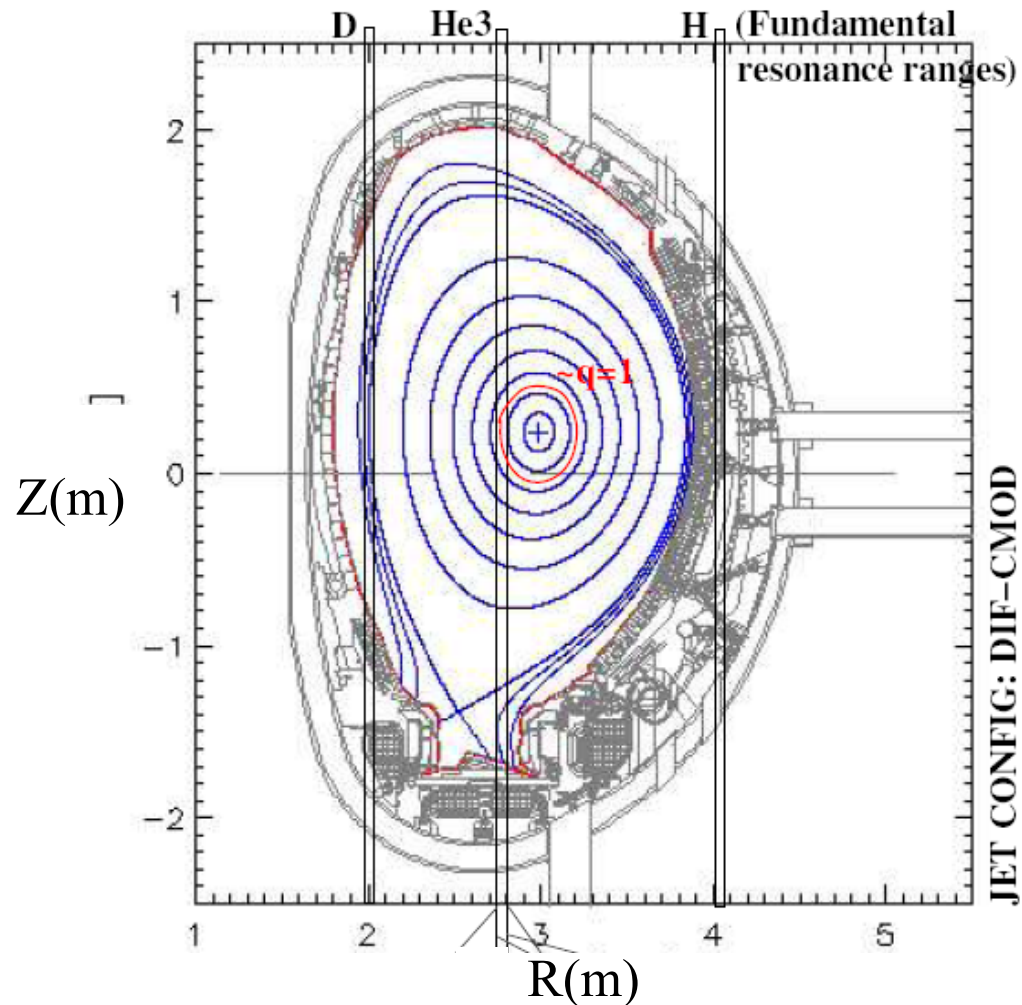

ITER relevant JET experiments have recently been devised employing minority ^3He . Until now it was thought minority ^3He could not generate sufficient current drive in order to affect sawteeth. Luckily the new fast ion mechanism doesn't require net driven current.





Sensitivity to the ^3He resonance position

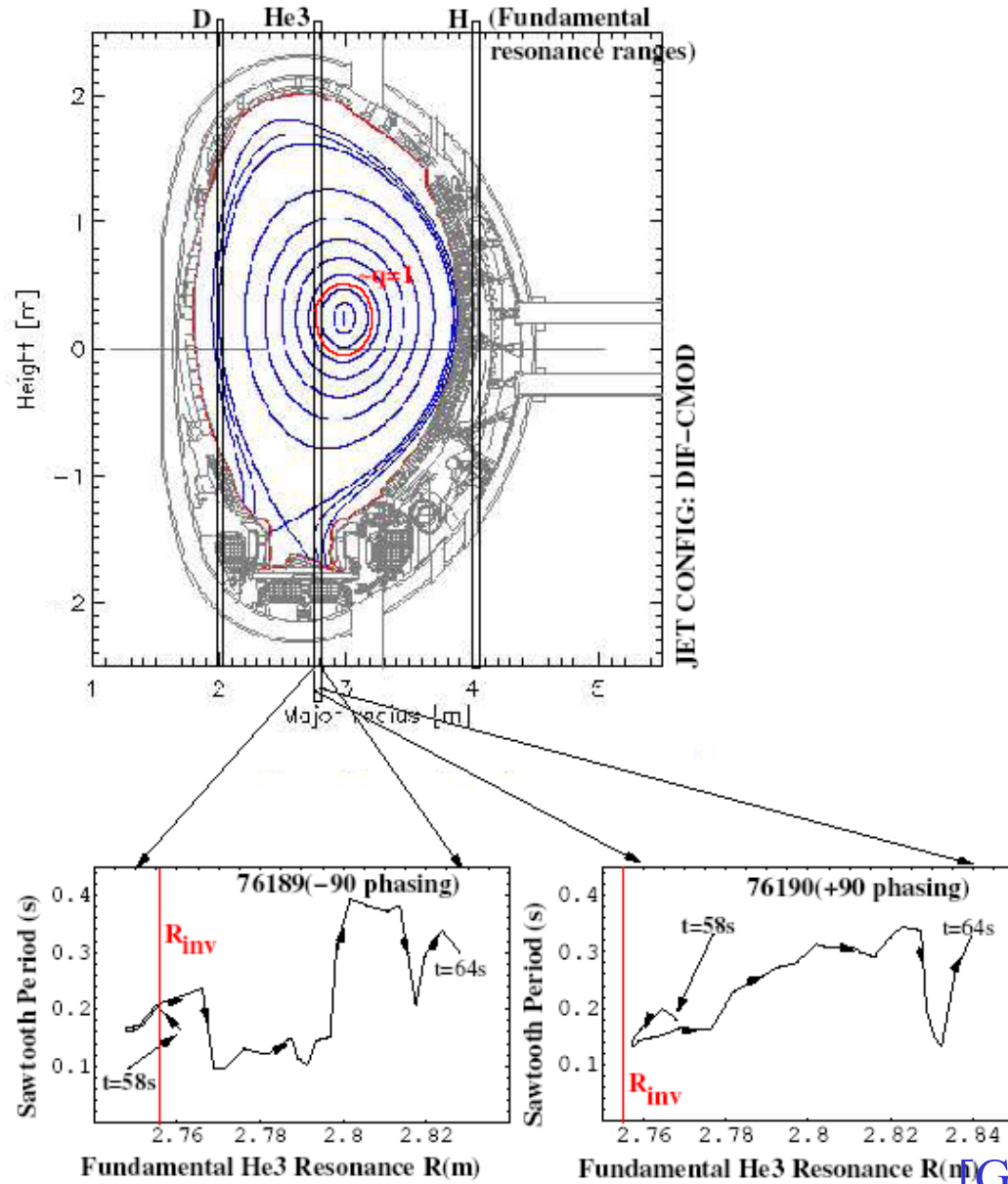

cntr-propagating waves

co-propagating waves



[Graves et al, NF 2010]

J. P. Graves, IISS, Austin, 31 May – 4 June 2010



Verification of Fast Ion Mechanism(1)

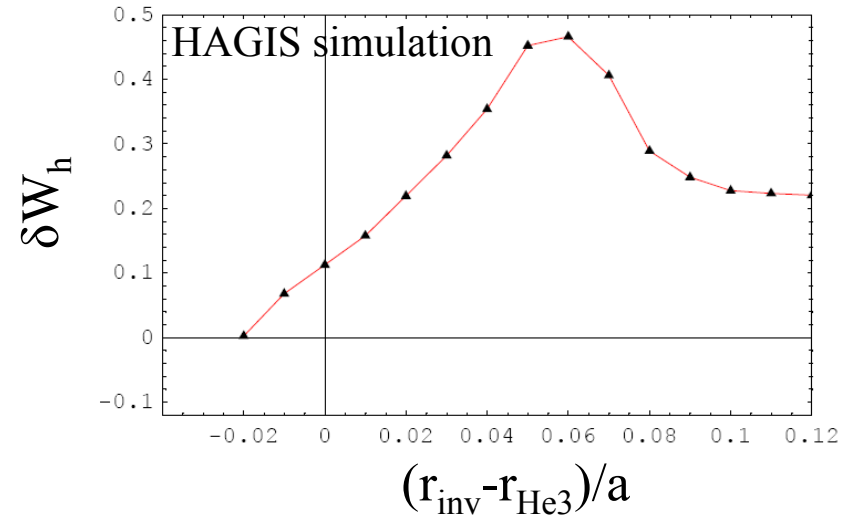
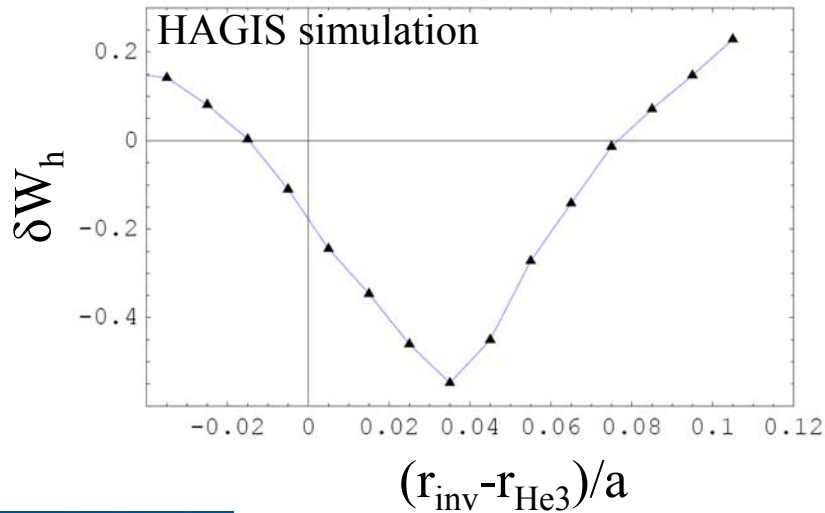
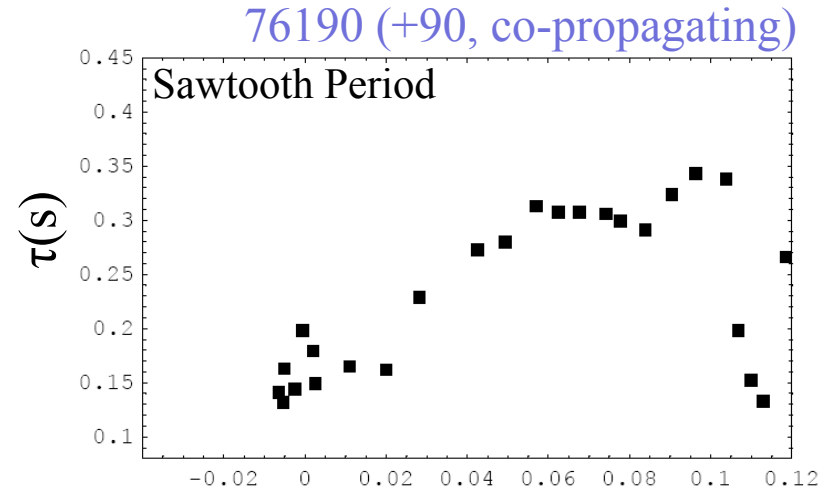
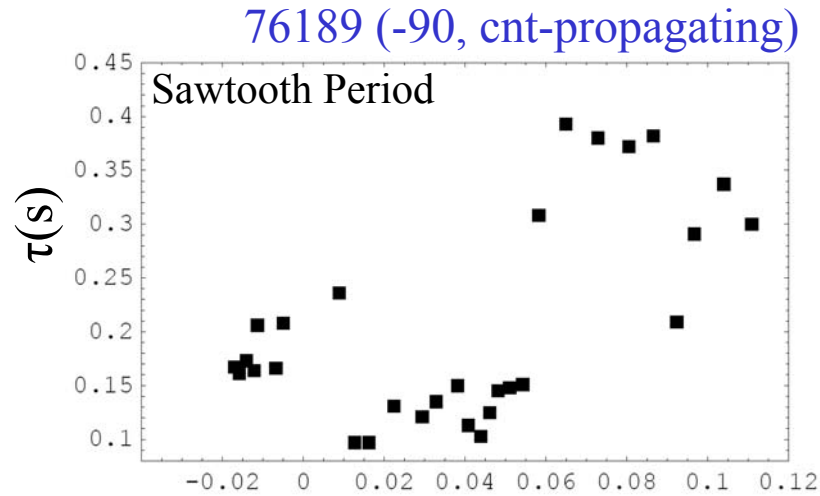

[Graves et al, NF 2010]

J. P. Graves, IISS, Austin, 31 May – 4 June 2010



Repeat with Higher Auxiliary Power

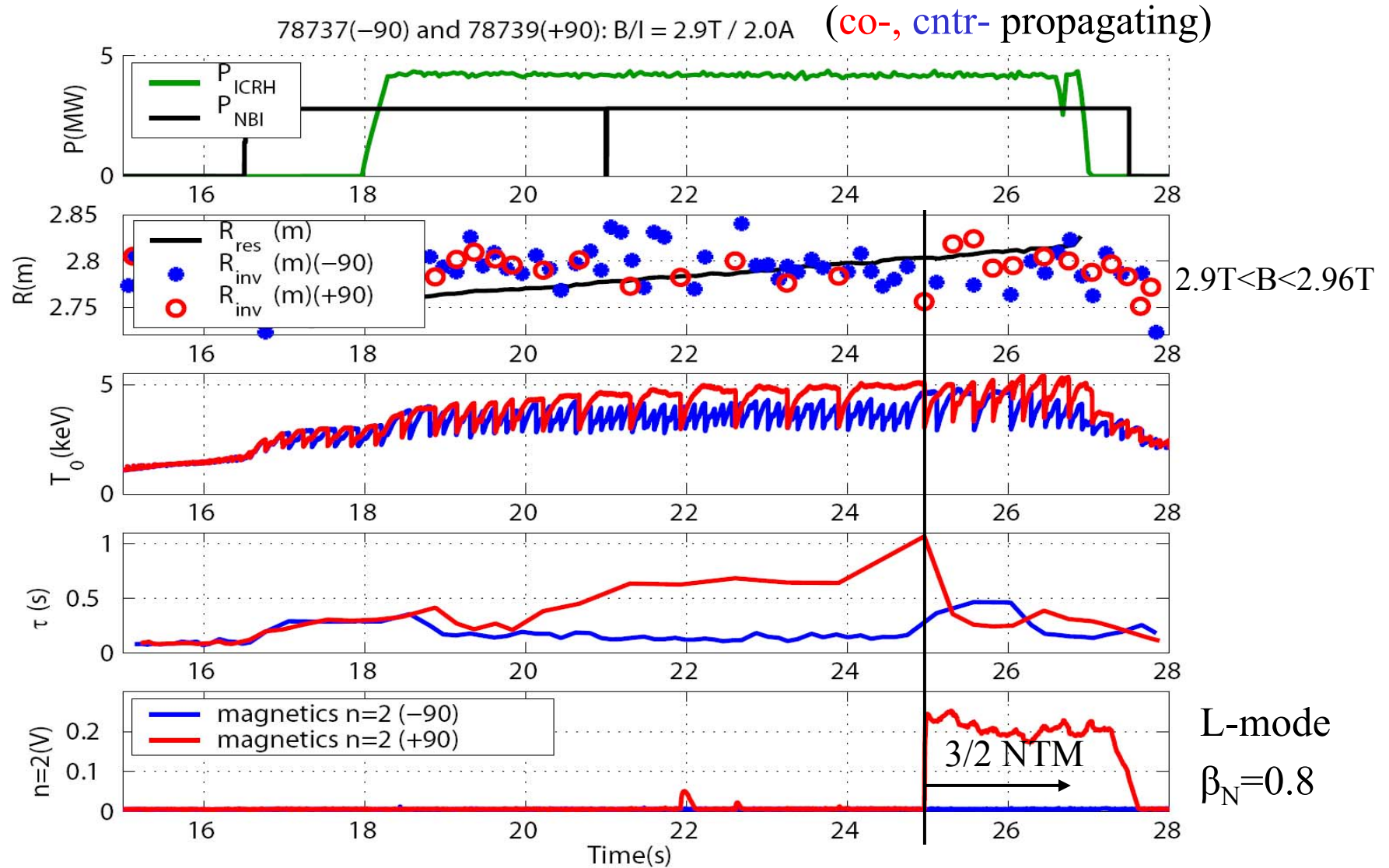

[Graves et al, NF 2010]



J. P. Graves, IISS, Austin, 31 May – 4 June 2010



ICRH in ITER

ITER will usually operate at full field (5.3T)

The primary minority will be ^3He during DT phase.

With the antenna range 40-55MHz, the minority ^3He will be on the low-field side (LFS) at full field. For this reason, we are attempting simulations, and JET experiments with resonance on the LFS

[Laxåback, NF 45, 1510 (2005)]

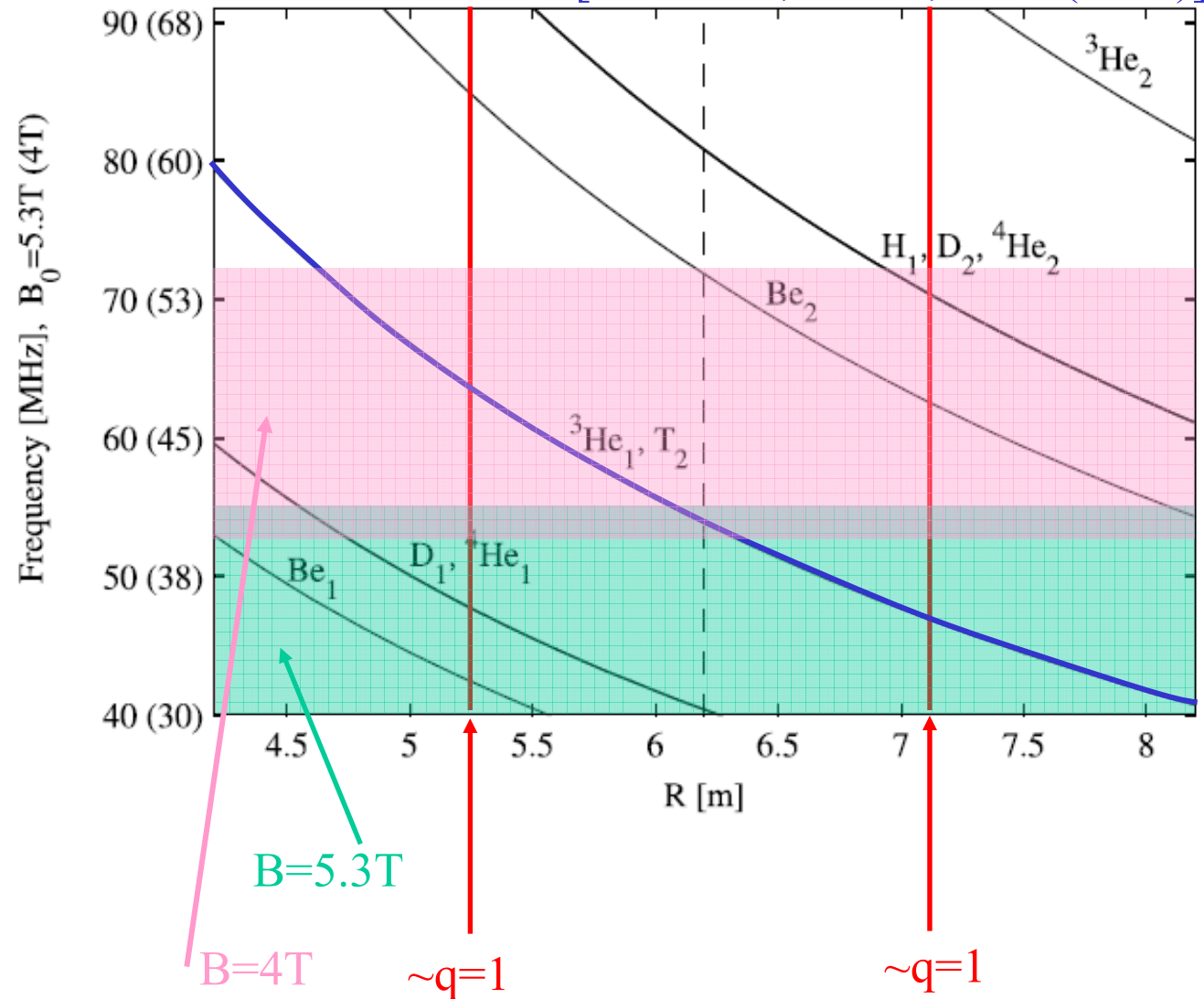



ICRH in ITER

- The antenna range in ITER is 40-55MHz, compared to 28 – 51MHz in the JET A2 antennas. As a result, resonance will have to be on the high field side. There will be less passing ions close to the trapped-passing boundary, and probably less control on sawteeth.
- Moreover, it will not routinely be possible to ramp the toroidal magnetic field in ITER, even by 2 percent over the pulse, as was done in the JET experiments here. There would be considerations on the power supply: 1 percent drop in the field over the pulse length would remove 2 percent of the energy, about 1GJ, so 10MW over 100s. This would lead to fatigue issues, unless undertaken only a few hundred times.
- However, it seems that some of these restrictions are offset by the excellent real-time control possibilities of the ICRH system in ITER. In JET, it is only possible to change the antenna frequency by 500KHz (less than 5 percent of minor radius), over a few seconds. This has made real-time control a real challenge. **But, in ITER, it will be possible to rapidly change the frequency by 2MHz (about 15 percent of minor radius).**



Conclusions

- The control of sawteeth is expected to be particularly important in ITER. NTMs triggered by long sawteeth have impaired fusion power in JET.
- In TCV and TORE-SUPRA, advanced real-time techniques have been developed to control sawteeth by manipulation of magnetic shear, even in the presence of fast ions.
- In ITER, it remains to be seen how effective shear control will be. An alternative control approach involves fast ions with asymmetric distribution in the parallel velocity.
- Mechanism explained NBI sawtooth control experiments in various machines.
- Realising the importance of barely passing ions, the work has been extended to treat toroidally propagating ICRH minority ion populations.
- Further verification of the fast ion mechanism was achieved by creating experiments capable of eliminating all other known control mechanisms.
- Used techniques to destabilise monster (NBI lengthened) sawteeth in H-mode.
- That fast ions can so dramatically, and directly, affect sawteeth is encouraging for ITER. In JET, ITER-relevant real-time sawtooth control using ICRH has had some success [M. Lennholm, to be published]